

# Final report

## FUSE - Frederiksberg Urban Smart Electromobility



## 1. Project details

<b>Project title</b>	FUSE - Frederiksberg Urban Smart Electromobility
<b>File no.</b>	64020-1092
<b>Name of the funding scheme</b>	EUDP
<b>Project managing company / institution</b>	DTU Wind
<b>CVR number</b> (central business register)	DK30060946
<b>Project partners</b>	Frederiksberg Kommune, Radius, COWI, Dansk e-Mobilitet, Elbilfor- eningen, Electricity Maps, SPIRII, DTU
<b>Submission date</b>	05 December 2024
<b>Resubmission date</b>	29 November 2024

## 2. Summary

### Project summary

#### The purpose of the project

The transition to a mass market for electromobility requires a significant investment in the Danish charging infrastructure and is of great importance to both the transport and energy sectors. Both sectors play a central role in Denmark's goal of reducing carbon dioxide (CO<sub>2</sub>) emissions.

The overall goal of the Frederiksberg Urban Smart Electromobility (FUSE) project has been to accelerate investments in the necessary charging infrastructure by developing and demonstrating new innovative charging solutions across the value chain of stakeholders, as well as establishing a strategic rollout plan for sufficient and smart charging infrastructure in urban environments.

To achieve this, the project has demonstrated the use of smart charging in the complex and densely populated environment of Frederiksberg Municipality. The project has also developed insights and tools to plan the expansion of urban charging infrastructure to meet future demand in Frederiksberg.

The project aims to pave the way for the experiences and solutions developed in Frederiksberg to be applied and utilized in other Danish cities.

#### Results, conclusions and perspective

The key insights from the project are:

- The charging infrastructure should be developed by expanding both normal and fast charging infrastructure in parallel, as these two types complement each other. In combination they can meet the needs that densely populated cities will face in the future.
- Smart charging can be a double-edged sword. Coordinated charging can potentially strain the distribution network by increasing the simultaneity of charging. However, this can be addressed by introducing market products that adjust consumption according to local capacity. This will enable a faster and more economical implementation of charging infrastructure in cities.
- Even in a densely populated environment like Frederiksberg, it is possible to establish sufficient charging infrastructure to enable all Danes to switch to EVs from a charging availability perspective.

The key results of the project include:

- The development of the Charging Point Calculator tool, which can provide all municipalities in the country with a rough estimate of the need for charging infrastructure.
- Analyses that provide insights into the considerations that should be included in the future expansion of charging infrastructure. This includes forecasts of usage rates over time and space, as well as the perceived availability of charging infrastructure for citizens.
- Analyses of the impact on cables and transformers in Frederiksberg from EV charging now and in the future.
- The formulation and testing of new products for limited grid access in collaboration between Radius and DTU.
- Calculations of potential CO<sub>2</sub> savings from smart charging with maximum use of green energy.
- Contributions to and the design of a large national survey on EV charging infrastructure.

The experiences and results will be carried forward by the project's participants in their work on charging infrastructure while also being continued in a new series of national and European research projects.

## Projektresumé

### Formålet med projektet

Overgangen til et massemarked for elektromobilitet kræver en betydelig investering i den danske ladeinfrastruktur og har stor betydning for både transport- og energisektoren. Begge disse sektorer spiller en central rolle i Danmarks målsætning om reduktion af CO<sub>2</sub>-udledning.

Det overordnede mål for FUSE (Frederiksberg Urban Smart Electromobility) projektet har været at fremskynde investeringer i den nødvendige ladeinfrastruktur ved at udvikle og demonstrere nye innovative ladeløsninger på tværs af værdikæden af aktører samt at etablere en strategisk udrulningsplan for en tilstrækkelig og smart ladeinfrastruktur i bymiljøer.

For at opnå dette har projektet demonstreret anvendelse af smart opladning i det komplekse og tæt befolkede miljø i Frederiksberg Kommune. Projektet har også udviklet indsigter og værktøjer til at planlægge udvidelsen af den urbane ladeinfrastruktur, så den kan imødekomme den fremtidige efterspørgsel på Frederiksberg.

Projektet skal bane vejen for, at de erfaringer og løsninger, som udvikles på Frederiksberg, kan anvendes og nyttiggøres i andre danske byer.

### Resultater, konklusioner og perspektiv

De vigtigste erfaringer i projektet er:

- Ladeinfrastrukturen skal opbygges ved at udbygge både normal- og lynladeinfrastrukturen parallelt, da de to typer infrastruktur supplerer hinanden. I kombination kan de dække det behov, som de befolkningstætte byer vil møde i fremtiden.
- Smart opladning kan være et tveægget sværd. Koordineret opladning kan potentielt belaste distributionsnettet ved at øge samtidigheden for opladning, dette kan dog imødekommes ved at introducere markedsprodukter som tilpasser forbruget i forhold til den lokale kapacitet. Dette vil muliggøre en hurtigere og mere økonomisk implementering af ladeinfrastrukturen i byerne.
- Selv i et tæt bymiljø som Frederiksberg, hvor elbiler har de sværeste betingelser for opladning, er det muligt at etablere tilstrækkelig ladeinfrastruktur, som giver alle danskere mulighed for at skifte til elbil, set ud fra et ladeperspektiv.

De vigtigste resultater i projektet er:

- Værktøjet Ladepunktregneren, som kan give alle landets kommuner et groft estimat af behovet for ladeinfrastruktur.
- Analyser, som giver indsigt i, hvilke overvejelser der bør indgå i den fremtidige udvidelse af ladeinfrastrukturen. Dette inkluderer prognoser for anvendelsesgrader over tid og sted samt den oplevede tilgængelighed af ladeinfrastruktur for borgerne.
- Analyser af påvirkningen af kabler og transformere i Frederiksberg fra elbilsopladning nu og i fremtiden.
- Formulering og test af nye produkter for begrænset netadgang i samarbejde mellem Radius og DTU.
- Beregninger af mulige CO<sub>2</sub>-besparelser ved smart opladning med maksimal anvendelse af grøn energi.
- Bidrag til og udformning af en stor national spørgeskemaundersøgelse om ladeinfrastruktur til elbiler.

Erfaringer og resultater bliver videreført af projektets deltagere i deres arbejde med ladeinfrastruktur, samtidig med at arbejdet fortsættes i en ny række nationale og europæiske forskningsprojekter.

### 3. Project objectives

The overall objective of the project is to accelerate investments in charging infrastructure by developing and demonstrating innovative charging solutions across the value chain of stakeholders, and by establishing a solid deployment approach for the roll-out of sufficient and smart charging infrastructure in urban areas.

**Frederiksberg**

One Municipality – Many possibilities for electric vehicle charging

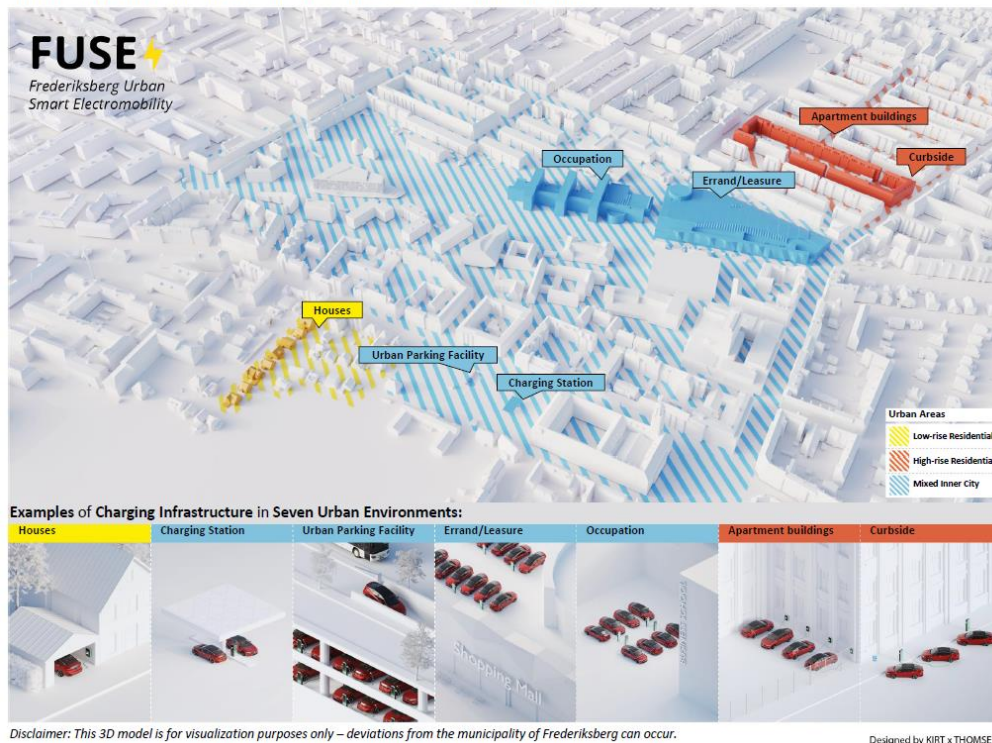

Fig. 1: Examples of charging infrastructure in seven urban environments

This objective is composed of two sub-objectives:

1. **Sufficient:** Establish an effective network planning strategy for charging infrastructure in urban environments (See Fig. 1). This will be achieved through in-depth analysis of parking options, availability, and usage, in close collaboration with infrastructure owners and users. The project aims to assess and identify cost-effective and efficient methods for meeting the expected charging demand. This will provide tangible input to charging infrastructure investors regarding location planning, expected infrastructure utilization rates, service levels, and user acceptance criteria. Furthermore, this will pave the way for the development of commercial planning tools.
2. **Smart:** Establish charger and charging solution requirements to achieve an infrastructure that not only supports the charging of EVs at satisfactory service levels but also integrates with the electricity grids. This will pave the way for realizing added value through reductions in grid reinforcement costs, new revenue streams from providing ancillary services via the chargers, and significant CO2 savings. The project will develop common requirements across the value chain of stakeholders and validate the charging infrastructure through demonstration activities.

The common technology for achieving the overall and sub-objectives is the charging spots themselves. The sufficiency objective addresses the type, number, and placement of charging spots, while the smart objective

focuses on the data and controllability capabilities of these chargers and the manner in which they are used to manage charging.

## 4. Project implementation

The project was carried out over 3.5 years (extended from 3 years) with a total of nine work packages. The responsibilities of the work package leaders were distributed among the partners.

A general risk to the project was its planned duration of 3 years, which is a long time in a domain such as charging infrastructure rollout, characterized by urgency and rapid development. This posed the risk of project findings and results becoming redundant due to market changes or disruptions. Another risk was the project's ambitious aim of conducting a suite of in-field demonstrations.

The following three challenges were met by the project:

1. COVID-19 impacted the project at a critical stage, preventing physical meetings during the early stages when such meetings are especially valuable for coordination purposes.
2. The project was challenged by many changes among project partners, with several substitutions and internal changes in personnel. This delayed and halted some of the project's activities. In most cases, this was ultimately resolved by reallocating tasks to new partners or employees.
3. Demonstration activities were delayed because the combined efforts of preparation, testing, and implementation took longer than anticipated. This also reduced the scope of the demonstrations carried out.

The project also foresaw major disruptions in charging technologies as a possible risk. Findings could have become outdated by the end of the project if charging technologies evolved very rapidly, but this ultimately did not turn out to be the case.

Except for delays in demonstration activities, which necessitated a six-month extension of the project, most other deadlines and milestones were met as planned. Overall, the project was carried out as intended.

## 5. Project results

### 5.1 Overview of research results

The following section outlines the key findings of the project, categorized into five distinct research areas:

- Survey on EVs and charging infrastructure in Denmark.
- Charging infrastructure planning for densely populated urban areas.
- Grid impact of EV charging on urban power distribution networks.
- Real-life demonstration of grid-friendly smart charging for public charging infrastructure.
- Quantification of potential emission savings from smart charging.

### 5.2 A user-friendly charging experience

User satisfaction is a key factor for the mass adoption of electromobility. To understand the existing barriers to widespread EV adoption, a survey was conducted in October 2022 in collaboration with the EV Association, FDM, and IDA. The survey gathered responses from 1,792 Danish car owners. Among them, 516 own an EV, 151 own a plug-in hybrid car (PHEV), and 1,410 own a petrol or diesel car. Some households own multiple cars, leading to a total exceeding 1,792. Most EV/PHEV owners have access to parking on their own property. The survey included questions about car type selection considerations, parking, charging, and charging infrastructure. Several key findings emerged from the study, which are highlighted below.

#### 5.2.1 Main findings

Main findings for a user-friendly charging experience:

- **Interest in EVs:** Nearly half of the drivers without an EV or PHEV are considering purchasing one, while another 40% have considered it but do not see it as a viable option currently. The price and range of EVs are the most important factors for both current EV owners and those without an EV.
- **Electricity Prices:** Rising electricity prices can impact the economics of owning an EV and potentially influence car type choice. In the autumn of 2022, when the data collection took place, the prices had not yet reached a level that caused EV owners to regret their decision. Ninety-two percent responded that rising electricity prices were of no importance or only of minor importance. In contrast, one in three non-EV owners said that rising electricity prices significantly impacted their decision not to choose an EV at the moment. However, the survey results indicate the awareness of changing electricity prices which might spark interest in cost-based smart charging which will be assessed in Chapter 5.4.
- **Differences in Perceptions Between EV Owners and Non-Owners:** There is a stark contrast between the perceptions of EV owners and those who do not own an EV. A significant majority (73%) of EV owners are satisfied or very satisfied with the range, whereas only 24% of non-EV owners share this sentiment, indicating that concerns about range may be more perception than reality. EV owners are also noticeably more satisfied with the availability of charging stations near their home, workplace, or along highways. This difference may stem from the fact that 92% of EV owners find their driving experience meets expectations, and 90% had a positive experience on their last long EV trip.
- **Public Charging Infrastructure Satisfaction:** Public charging infrastructure remains a major concern for EV/PHEV owners. Only 21% are satisfied or very satisfied with public charging infrastructure in Denmark, while 42% are dissatisfied or very dissatisfied. The opportunity for curbside charging near home or for away-from-home purposes received the lowest satisfaction, with only 5% stating that there are good charging opportunities. Additionally, satisfaction with charging at fast-charging stations for daily driving, at large public parking facilities, or while shopping is low, with only 16%, 17%, and 11% respectively rating these options as good or very good. Only one in four EV/PHEV owners think the

charging options at workplaces or educational institutions are good, while about half are satisfied with fast charging stations for long journeys. These findings highlight the importance of deploying public charging infrastructure, especially in urban areas where many people live in multi-story buildings without the possibility of parking on their own property. These residents face more difficult charging conditions on the road where they live or around the city during the day, which most describe as suboptimal.

- **Charging Behavior:** Charging behavior differs among EV users. For those with access to home charging, 30% charge 1-2 times a week, 22% charge 3-4 times a week, and 37% charge more than 5 times a week.

## 5.3 Charging infrastructure for Danish cities

As highlighted in the previous chapter, sufficient charging infrastructure remains a significant issue, especially in urban areas with limited access to home charging. However, the effective planning and optimization of charging infrastructure is a complex task, as it requires simulating EV user behavior and interactions, which presents several challenges.

To start with, the placement and sizing of chargers are non-trivial tasks that require analyzing traffic patterns and urban planning parameters to find the right balance between fast and slow charging stations. Moreover, the inherent uncertainty in EV adoption rates, advancements in efficiency, battery range, and charging technology complicates accurate projections and planning. Additionally, user behavior—including preferences for fast or slow charging, tolerance for waiting times, and initial state-of-charge—significantly affects the performance and utilization of the charging network. Furthermore, complex queuing dynamics at public charging stations require sophisticated modeling to manage congestion and ensure user satisfaction.

To address these challenges, an agent-based simulator called GAIA was developed in the FUSE project. GAIA uses synthetic agents with realistic trip diaries, calibrated to local socio-demographics and public transport flows. It models microscopic movements in a space-time domain and monitors entry and exit from various queuing systems. The model includes a decision framework that mimics human behavior and is applicable to diverse driving patterns. It monitors home, fast, and public slow charging utilization and allows agents to reassess decisions based on real-time system use. GAIA tracks both observed choices and intentions to charge, quantifies unserved demand, incorporates realistic EV consumption and charging models, and converts results into key performance indicators (KPIs) to assess service level and quality.

### 5.3.1 Results

GAIA explored various future scenarios for urban charging infrastructure. Initially focused on Frederiksberg, simulations revealed that the municipality could not be modeled in isolation. Consequently, the framework was expanded to cover most of the Capital Region of Denmark, analyzing charging infrastructure demand and supply for both Frederiksberg and Copenhagen. Currently, development has focused primarily on slow AC charging, with 1,994 slow charging outlets versus 52 fast charging outlets in Frederiksberg and Copenhagen as of 2023. However, as demand increases, a shift towards fast chargers, which are more efficiently utilized, will likely be necessary. The framework examined the feasibility of meeting the growing demand, projecting up to a 40% EV adoption rate by 2030, by expanding publicly accessible fast charging infrastructure and private home charging, while maintaining a given level of slow chargers. The growth of fast chargers was simulated by increasing the number of outlets at existing fast charging stations. The results of this analysis are highlighted in the following.

#### 5.3.1.1 Viable future scenarios

Real-world utilization data shows that with the 2024 EV adoption rate of approximately 6% in Frederiksberg and Copenhagen, the population is fully served with reasonable waiting times and minimal unserved demand.

Therefore, the current service level, measured in terms of the rate of daily unserved demand and maximum waiting times during peak demand, serves as a benchmark for future infrastructure deployment as EV adoption increases. To maintain this service level, both the daily unserved demand rate and the maximum waiting times during peak demand are used as reference thresholds. The latter is assessed using the 99th percentile of waiting times, with a target window of 5 to 15 minutes. Results indicate that demand can be met up to 2030 by expanding existing fast charging stations to a minimum of 12 outlets at 22 locations in Frederiksberg and Copenhagen.

Fig. 2 illustrates maximum waiting times as a function of the minimum number of outlets at fast charging clusters for different EV adoption rates. Configurations marked by black circles indicate scenarios where both demand and quality of service are satisfied, while crosses denote scenarios where either the infrastructure is underdeveloped, leading to high waiting times, or over-supplied, resulting in sub-optimal utilization. At the lower bound of 30% adoption for 2030, at least 10 outlets per fast charging cluster are required, yielding an effective maximum waiting time during peak demand of approximately 8 minutes. In contrast, at the higher bound of 40% adoption, 12 outlets per cluster are required with a waiting time of 10 minutes.

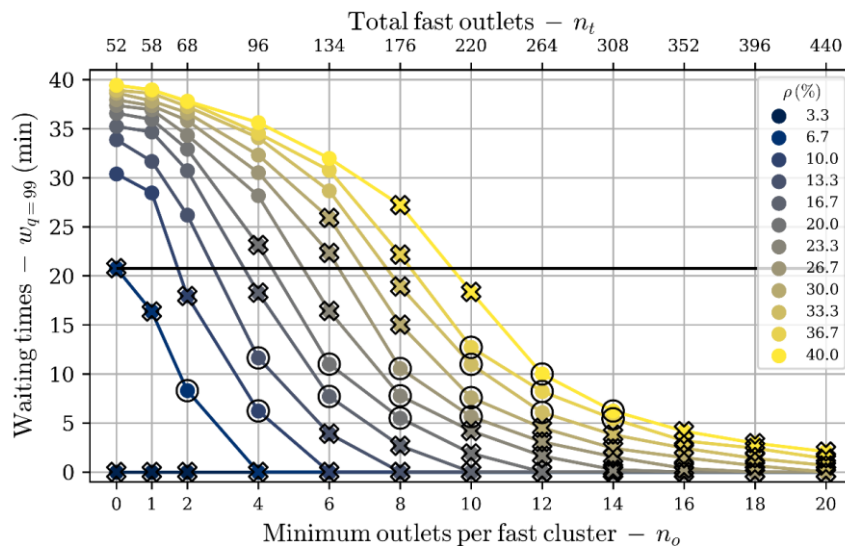

Fig. 2: Maximum waiting times as a function of the minimum number of outlets at the fast charging clusters. Different colors depict the EV adoption rate (ρ%). The black solid line shows the present maximum waiting time. Black circles indicate scenarios where demand is served and maximum waiting times are within 5 to 15 minutes, while crosses indicate scenarios where demand is met, but maximum waiting times are outside this target window.

### 5.3.1.2 Utilization and infrastructure dimensioning

Concerning efficiency, the results indicate the potential of doubling current fast charger utilization from roughly 16 to 32 events per day per outlet without saturating the system.

Additionally, slow chargers, currently with below 1 event per day per outlet, could see approximately 3.5 events per day. At a 40% EV adoption rate, this translates to a daily throughput of 7,378 EVs on slow chargers and 8,448 EVs on fast chargers in Frederiksberg and Copenhagen.

This efficiency increase arises because slow chargers no longer need to meet peak demand; instead, they can handle steady-state demand throughout the day. Fast chargers, with shorter waiting times at larger stations, can manage peak demand while maintaining a good user experience.

It is important to note that size is a critical factor. Smaller clusters with fewer than four outlets increase waiting times during peak demand due to less reliable waiting time predictions. The results indicate the minimum size

for a fast charging station should be 4 outlets, but a good quality of service requires 8 to 14 outlets plus additional queuing space. Smaller clusters should accommodate queuing for 3 to 4 cars, while larger clusters require space for 1 or 2 cars.

In addition to the surprisingly positive impact on the slow charging infrastructure, developing fast charging clusters also reduces the concentration of demand in time and space. Agents prefer to utilize fast charging between activities, meaning they do not have to interrupt other activities to fulfill their charging needs. Therefore, the effective radius of a cluster of fast chargers is much larger than that of slow chargers, which are often limited by acceptable walking distances for car users.

A final note concerns the 3-hour parking limit at slow chargers between 9:00 and 20:00, which is crucial to achieving 3.5 events per day; otherwise, utilization drops to as low as 1 event per day per outlet. While 3 hours satisfy the charging demand for the majority of users, shorter parking limits may slightly increase slow charging utilization but negatively impact many users by preventing them from fully satisfying their demand. In contrast, limits greater than 3 hours marginally improve service for a small share of users but at the cost of overall efficiency and significantly reduced utilization of slow chargers.

**5.3.1.3 Information sharing**

Physical infrastructure is crucial for meeting demand, but service quality can be significantly improved by providing users with real-time information on charging infrastructure utilization. This access enhances decision-making and reduces congestion at high-demand hotspots. In this simulation framework, information sharing includes the number of outlets, EVs being served, and queue sizes. The results in Fig. 3 demonstrate that information sharing can reduce maximum waiting times by up to a third. These benefits persist even when agents use alternative methods to manage the lack of information, as shown by the three different curves.

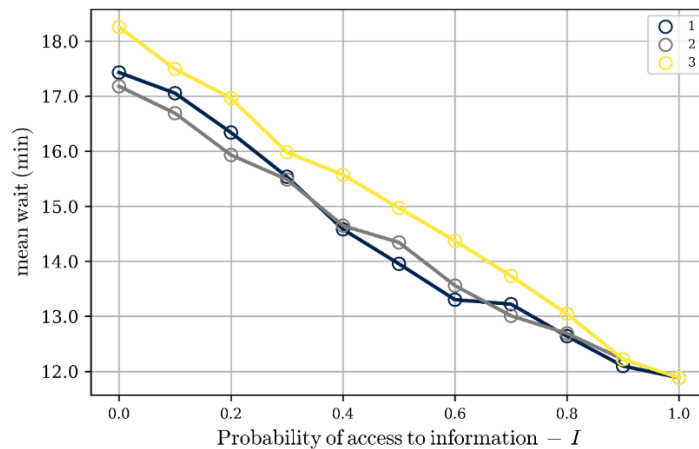

Fig. 3: Maximum waiting time as a function of probability of access to information on charging infrastructure status. At zero probability, no agent has access to charging station status; at 1, all agents have access. The three curves, labeled 1 to 3, show alternative methods that agents can use to estimate service and wait times in the absence of information.

**5.3.1.4 Censored demand**

GAIA simulates the entire decision process of an agent, capturing both the energy charged and instances where desired charging events couldn't be satisfied. This decomposition of total demand into observed and censored/unserved parts is crucial for assessing infrastructure service levels. Fig. 4 visualizes the mismatch between current supply and forecasted 2030 demand, highlighting where demand will emerge and optimal charger placement so that demand can be served with minimal detours.

It is important to note that slow and fast chargers have very different effective service radius. This difference primarily arises because users typically stay in or near their cars while using fast chargers, whereas slow

charging services require parking the car and walking to a destination. Hence, the latter is limited by the effective walking distance, while the former is limited by how far the driver is willing to detour from their initial location. Therefore, slow charging infrastructure will always need to be placed where demand exists, which in turn induces further demand. In contrast, fast chargers can be strategically deployed to disperse demand and minimize induced demand.

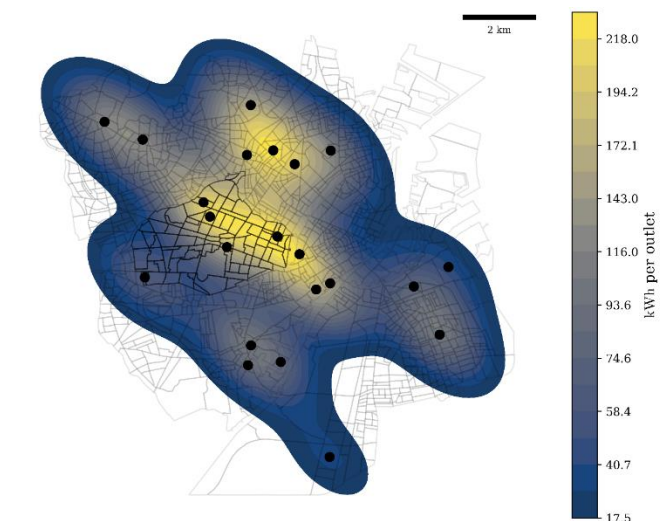

Fig. 4: Geographical distribution of unserved (censored) demand expressed in energy per fast charging outlet in Frederiksberg and Copenhagen per day based on current supply and predicted demand in 2030. Dots indicate the location of current and future fast charging stations.

### 5.3.1.5 Demand agnostic KPIs

The results from GAIA indicate that demand-agnostic KPIs like installed power per EV are insufficient for assessing service levels. These metrics overlook the dynamic aspects of the problem, including queue overflow, scale effects, daily demand fluctuations across different times and locations, and intercity traffic flows. Nevertheless, the findings suggest that the necessary installed capacity per EV will decrease and align to values approximately 50% higher than the EU guideline of 1 kW per EV. However, slight variations in this KPI can lead to starkly different 2030 scenarios; for instance, 1.3 kW per EV would indicate severe under-supply, whereas 1.6 kW per EV would imply an overbuilt infrastructure. Therefore, infrastructure utilization should be the primary KPI. Ideally, dimensioning the system should correspond to approximately 2 events per day per outlet in slow chargers and 16 to 32 events per day per outlet at fast charging clusters. It is also important to track the waiting times at the fast charging infrastructure as an alternative KPI.

### 5.3.2 Main findings and recommendations

Based on the results presented above, several main findings and recommendations are highlighted below.

- **The future will be different, and we will have to adapt!** EVs have a shorter range than internal combustion engine (ICE) vehicles and require a different type of infrastructure, which is challenging to implement in urban areas with limited space and diverse uses, where power grid stress can be an issue. While some can charge their car at home, most people in dense urban areas must plan their charging around daily routines, such as shopping or errands. Users may occasionally experience moderate wait times (under 15 minutes) and must walk to nearby charging stations. This study demonstrates that, overall, behavioral adaptation is minimal if the infrastructure is properly designed. With sufficient infrastructure, waiting times can be minimized, walking distances to slow chargers kept acceptable (mostly under a few minutes), and few will need to make longer detours when seeking charging options.

- **Fast charging in combination with home charging has strong potential.** One lesson from this work is that fast charging has the potential to play an important role in fulfilling future charging needs. Rule of thumb optimal metrics suggest that on average, fast and slow charging is expected to serve the same total daily number of cars but with a ratio of at least 8 slow chargers per fast charger, in the most efficient scenarios. This is due to multiple reasons:
  - Fast chargers cover larger areas, making them easier to deploy without compromising system efficiency.
  - Slow chargers, as opposed to fast chargers, have a limited ability to meet the peak load. It will require a large number to meet the demand. Fast chargers on the other hand, have much better utilization and facilitate peak demand scenarios much more efficiently. Hence, the expansion of slow chargers will ultimately erode the efficiency and utilization of the charging infrastructure.
  - Organizing fast charging infrastructure into fewer clusters can reduce costs, improve service levels by predicting waiting times better, and potentially accommodate additional waiting facilities.
  - Well-sized fast charging clusters can connect directly to higher voltage levels, potentially reducing strain on lower voltage grids and avoiding costly upgrades.
  - Widespread adoption of slow chargers intensifies competition for limited normal parking spaces, leading EV users to use charging infrastructure for parking, thereby reducing overall public infrastructure efficiency.
- **Unserved demand can be a good indicator for future charging infrastructure placement.** Unserved demand, defined as charging intentions that were not met, proves to be a reliable indicator for locating future charging infrastructure. This approach outperforms strategies based solely on observed demand.
- **Information sharing is important for improving the utilization of the system.** It is demonstrated that the sharing of information can reduce waiting times and improve utilization. The fact that people are informed (in real time) empowers users to choose alternative options, which circumvent the most critical queuing regimes. This highlights the importance of charging operators sharing station load and waiting time information in real-time.
- **Smart charging might be problematic for efficient public charging infrastructure utilization.** Smart charging is most effective when EVs are plugged in for extended periods. However, policies that incentivize longer charging sessions can reduce the efficiency of public charging infrastructure. Since the primary goal of charging infrastructure is to meet as much demand as possible, smart charging should be encouraged primarily during times when EVs are naturally plugged in for longer periods, such as overnight charging. Additionally, it can be used to alleviate grid constraints and support the accelerated deployment of charging infrastructure.
- **Frederiksberg is on a good path.** By November 2023, Frederiksberg had 2,277 pure EVs, a 5.75x increase since the end of 2020. During the same period, the public slow charging infrastructure expanded to approximately 600 outlets, a 4.44x increase, with the addition of a fast charging clusters. Despite the apparent outpacing of infrastructure development by EV sales, many EV adopters have access to home charging, reducing their reliance on public infrastructure. Considering the fast charging outlets, the infrastructure growth (4.92x) nearly matches the increase in sales. The low utilization of public slow chargers (less than one event per day per outlet) indicates moderate oversupply, suggesting the municipality is slightly ahead in infrastructure development. However, it is important to stress that the system can quickly become saturated.

## 5.4 The role of the power distribution grid in electrification

The results of the GAIA model are particularly interesting from a PDN (power distribution network) perspective, as a shift from numerous curbside charging stations to fewer fast charging clusters will affect how the PDNs need to be expanded and reinforced. While the daily power demand for charging EVs will most likely remain the same, a shift could potentially offer direct savings for distribution system operators (DSOs), as the low voltage PDN (LVDN) would require less expansion compared to accommodating many curbside chargers. Instead, the work could be focused on establishing a few powerful 10 kV connections to the medium voltage PDN (MVDN) for the fast charging clusters.

While charging infrastructure planning will therefore have significant implications for the PDN, the need for reinforcements will also largely hinge on charging behavior, i.e. whether charging takes place simultaneously with other high consumption or during low load periods. The results of the GAIA model indicated that with high EV adoption, fast charging is expected to naturally spread throughout the day.. However, charging behavior at home remains uncertain. Initial concerns have focused on uncontrolled home charging and its potential negative impacts on PDNs, such as grid asset overloading, voltage violations, and phase imbalances. Smart charging could alleviate these issues by delaying or limiting charging to reduce peak loads. However, various forms of smart charging, including those tied to electricity prices, tariffs, CO2 footprint, and self-production, could potentially further intensify PDN stress by synchronizing charging times, possibly even on the same day. The impact and likelihood of such behavior on urban PDNs are still not well understood and will be discussed in the following, with the PDN of Frederiksberg serving as a case study.

### 5.4.1 Power distribution grid of Frederiksberg

The MVDN and three areas of Frederiksberg’s LVDN are depicted in Fig. 5. In normal operation (N), the MVDN functions as three separate networks with open tie-lines—labeled MV1, MV2, and MV3. Each grid is supplied by a 50/10 kV primary substation connected to numerous secondary 10/0.4 kV transformers (marked by red, blue, and black dots respectively). Medium voltage cables are depicted by green lines. Most of Frederiksberg’s LVDN operates in a meshed manner, where multiple transformers supply a defined area. However, the analysis concentrates solely on three selected islanded areas of the LVDN, each fed by a single transformer with a large share of single-family homes. These areas exhibit variations in size and topology, with LV1 being the smallest and LV3 accommodating the highest number of customers.

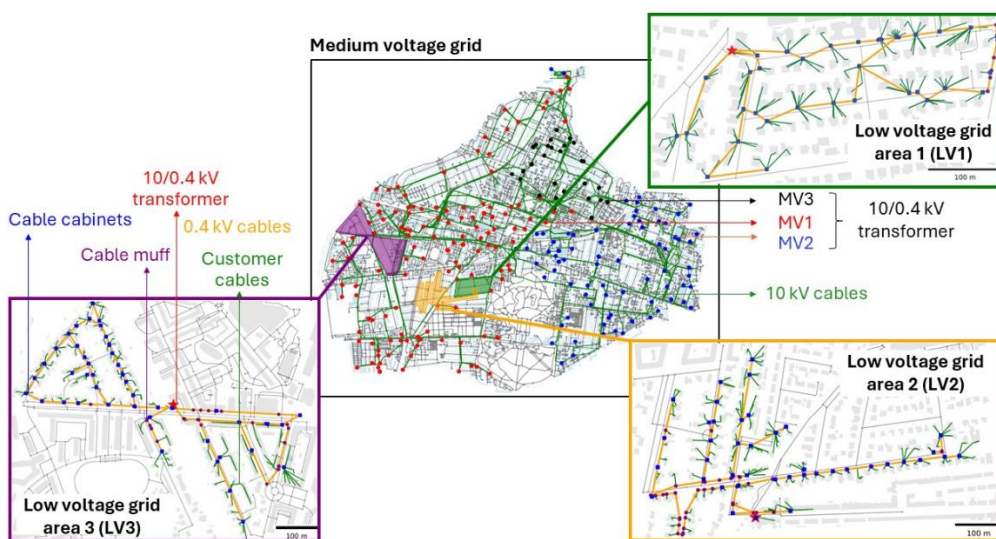

Fig. 5: PDN topology of Frederiksberg’s MVDN and three selected LVDN areas.

### 5.4.2 Charging scenarios

The charging scenarios are based on the agent-based simulator GAIA. While GAIA models uncontrolled charging, its outputs can also be used to simulate various charging behaviors. The MVDN study examines the impact of both home and workplace charging, assuming 100% EV adoption. As shown in Tab. 1, five different charging scenarios are assessed, investigating the impact of different charging patterns and behaviors: non-daily vs. daily charging, and uncontrolled vs. time-synchronized charging. For the synchronization scenarios, two different home charging start times are analyzed: a) midnight, to simulate a response to a Time-of-Use (ToU) tariff, and b) 18:00, to assess a worst-case scenario where charging coincides with peak MVDN consumption.

Tab. 1: Summary of the characteristics of each charging scenario in the MVDN, including sub-scenarios a and b.

	S <sub>1</sub>	S <sub>2</sub>	S <sub>3a</sub>	S <sub>3b</sub>	S <sub>4a</sub>	S <sub>4b</sub>	S <sub>5a</sub>	S <sub>5b</sub>
<i>frequency</i>	Non-daily	Daily	Non-daily		Daily		Non-daily	
<i>control</i>	No		Time-synchronized				Time & day-synchronized	
<i>start home</i>	Upon arrival		00:00	18:00	00:00	18:00	00:00	18:00
<i>start work</i>	Upon arrival		10:00		10:00		10:00	

In contrast, the LVDN study focuses exclusively on home charging, projecting a 2030 scenario with a 40% EV adoption rate. As depicted in Tab. 2, five different scenarios are investigated. Initially, the LVDN state is assessed without EVs. The first scenario mimics MVDN's S<sub>1</sub>, assessing the impact of non-daily uncontrolled charging. The second scenario models charging according to Tariff Model 3.0, introduced by the DSO Radius in January 2023, which features three pricing periods: highest tariffs from 17:00 to 21:00, and lowest costs from 00:00 to 06:00. The third scenario additionally incorporates electricity costs in the smart charging optimization. Finally, the fourth scenario mirrors MVDN's S<sub>5a</sub>, where all EVs charge on the same day, following the same cost-minimization strategy as in S<sub>3</sub>. Such synchronization events could be triggered by special days like public holidays or multi-day price forecasts, prompting EV users to charge on the same day, whereas they would otherwise spread charging over several days due to non-daily patterns.

Tab. 2: Summary of the characteristics of each charging scenario in the LVDN.

	S <sub>0</sub>	S <sub>1</sub>	S <sub>2</sub>	S <sub>3</sub>	S <sub>4</sub>
<i>frequency</i>	No EVs	Non-daily	Non-daily	Non-daily	Non-daily
<i>control</i>		No	Time-of-Use tariff	Time-of-Use tariff + Electricity spot price	
<i>start home</i>		Upon arrival	Simulated		
<i>similar MVDN scenario</i>		S <sub>1</sub>	S <sub>3a</sub>	S <sub>3a</sub>	S <sub>5a</sub>

### 5.4.3 Grid impact results

For each scenario, power flow simulations were conducted for 40 selected peak loading days in the MVDN and 1,000 iterations in the LVDN. Results were analyzed with respect to transformer loading, cable loading, and bus voltages. Given that no voltage violations occurred in any scenario, the analysis focuses on the impacts of transformer and cable loading. Fig. 6 highlights the results for the MVDN. The evaluation of transformer loading in Fig. 6 (a) involves assessing both the technical limit of 100% loading and the DSO's dimensioning criterion of 66% loading. The technical limit represents the maximum sustainable load, although transformers can handle temporary overloads beyond 100%. The dimensioning criterion ensures a transformer can supply neighboring grid sections during a single contingency (N-1) event.

The findings indicate that non-daily charging yields the lowest impact on the grid, even with synchronized start times. Scenarios S<sub>1</sub> to S<sub>3</sub> result in only about 14% and less than 1% of transformers violating the N-1 and

100% limits, respectively. Severe congestion occurs only in scenarios S<sub>4</sub> and S<sub>5</sub>, with approximately 63% and 80% of transformers exceeding the 100% and 66% thresholds, respectively. The results also highlight the impact of synchronization timing. With high EV adoption, synchronization at night could be more detrimental than during the evening peak, as most EVs are at home and could charge simultaneously. As indicated in Fig. 6 (b), cables also appear to be well dimensioned to handle increased home and workplace charging demand. Even in the extreme synchronization scenarios S<sub>4</sub> and S<sub>5</sub>, less than 6% of cables experience congestion. In scenarios S<sub>1</sub> to S<sub>3</sub>, no cables face overloading. Overall, barring extreme synchronization of charging on the same day and at the same time, the MVDN appears well prepared for a significant increase of home and workplace charging in the future.

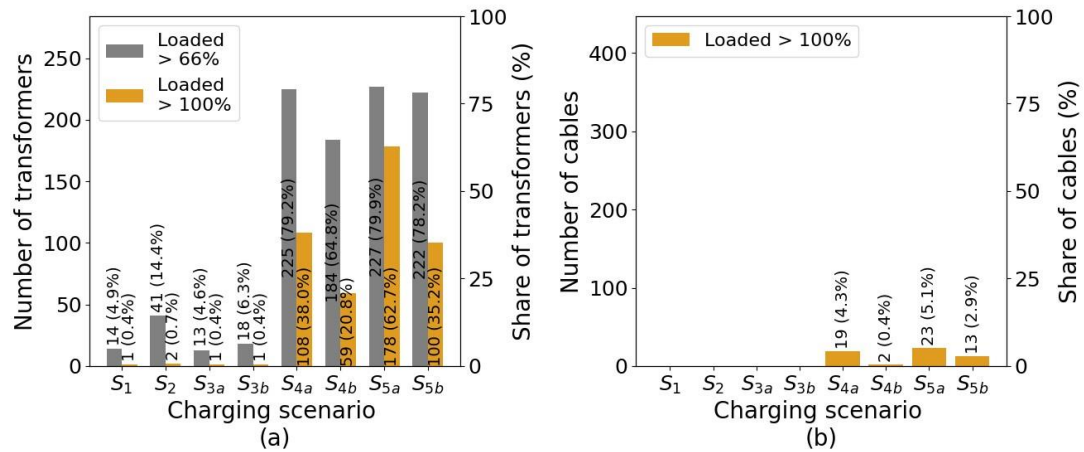

Fig. 6: Grid impact results for the MVDN across each charging scenario. Subplot (a) depicts the number and percentage of transformers exceeding their dimensioning (66%) and technical limit (100%), while Subplot (b) illustrates the number and percentage of cables experiencing congestion (>100% loading).

To highlight the differences between charging scenarios and their implications for the LVDN, the coincidence factor (CF) of charging is illustrated for each LVDN area and scenario in Fig. 7. The CF represents the proportion of EVs charging at a given time relative to the total EV population. Scenario S<sub>1</sub> exhibits the lowest CF, with medians and upper whiskers below 5% and 15%, respectively. This can be attributed to non-daily charging habits and the natural dispersion of EV arrivals and their charging initiation times. Scenarios S<sub>2</sub> and S<sub>3</sub> show a moderate increase in CF compared to S<sub>1</sub> due to charging synchronization, with medians and upper whiskers below 12.5% and 22.5%, respectively. The primary distinction between S<sub>2</sub> and S<sub>3</sub> is a slight delay in the peak CF occurrence. Scenario S<sub>4</sub> results in a substantial increase in CF, with upper whiskers ranging from 65% to 75%. The notable disparity between S<sub>3</sub> and S<sub>4</sub> arises from the shift from a non-daily charging pattern to a scenario where all EVs are synchronized to charge on the same day. When comparing CFs across the three LVDN areas, it is observed that with an increasing number of grid customers and EVs, the spread and magnitude of the CF tend to decrease, consistent with previous findings in literature.

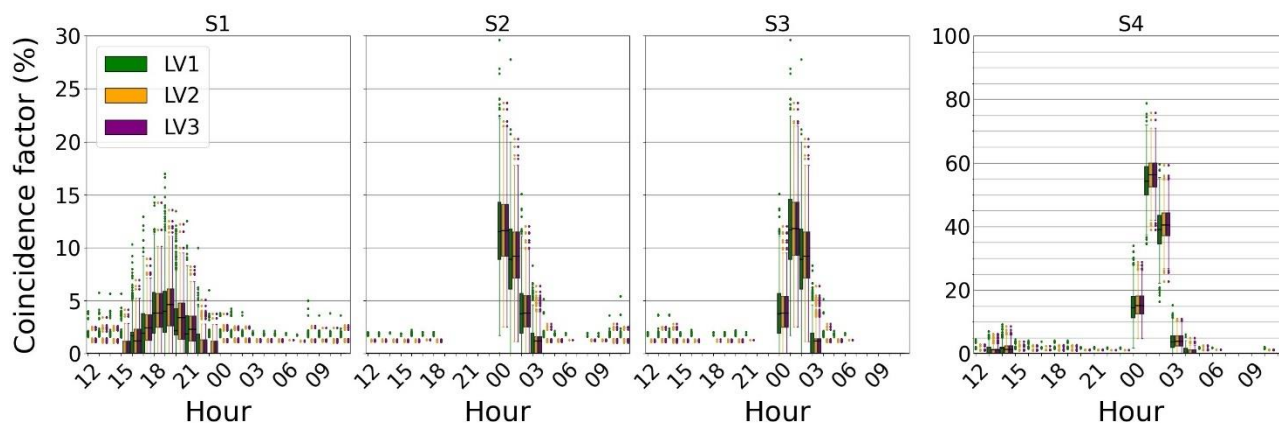

Fig. 7: Distribution of charging CF throughout one day for each charging scenario and LVDN area.

Transformer and cable loading are depicted in Figs. 8 and 9, highlighting two key findings. On the one hand, there are significant variations in grid impact across the three LVDN areas, primarily due to differences in size, topology, and asset dimensioning. LV1, the smallest LVDN area with the fewest customers but the largest transformer capacity (630 kVA), is a largely oversized grid today with ample spare capacity for EV integration in the upcoming years. In S0 transformer load remains consistently below 40%, with only one cable occasionally overloading. Only S4 causes notable congestion and occasional transformer overloading. In contrast, LV2 is a well-utilized LVDN today, hosting the second-largest number of customers and the longest feeders. In Scenario S0, peak load occasionally approaches or marginally exceeds the N-1 limit, with some cable segments already overloaded without EV charging. Scenarios S1 to S3 induce moderate increases in congestion and transformer loading, while S4 triggers significant congestion for both the transformer and a large share of cables. LV3 is the most constrained area, already facing transformer capacity issues with peak loading regularly exceeding 66%. Several cable segments experience daily congestion, and all charging scenarios lead to transformer overload events. This indicates that LV3 is the most susceptible to congestion and will require reinforcement or alternative load reduction strategies in the near future.

On the other hand, the charging behavior will significantly impact the LVDN and the associated socioeconomic costs for reinforcements. Scenario S1 shows, aligned with previous research, that uncontrolled charging can cause transformer and cable congestion even at modest EV penetration levels due to overlap with the evening peak. To address this, DSOs have implemented ToU tariffs to shift flexible loads to periods of lower grid demand. Scenario S2 confirms that ToU tariffs can reduce grid burden at low adoption rates by decreasing the likelihood, magnitude, and duration of congestion. Similarly, cost-based charging that aligns with natural EV user patterns can minimize the short-term LVDN impact and delay infrastructure upgrades. However, both strategies should be viewed as transitional measures. In the long term, they can lead to larger secondary peaks, which will be detrimental to the LVDN. Furthermore, if supported by multiday price forecasts or in combination with special days (i.e. public holidays), cost-based smart charging poses the risk of disrupting natural patterns and concentrating demand on a single day, as highlighted in Scenario S4. This scenario shows significantly higher transformer and cable congestion, leading to substantial investment costs, emphasizing the need to prevent such outcomes.

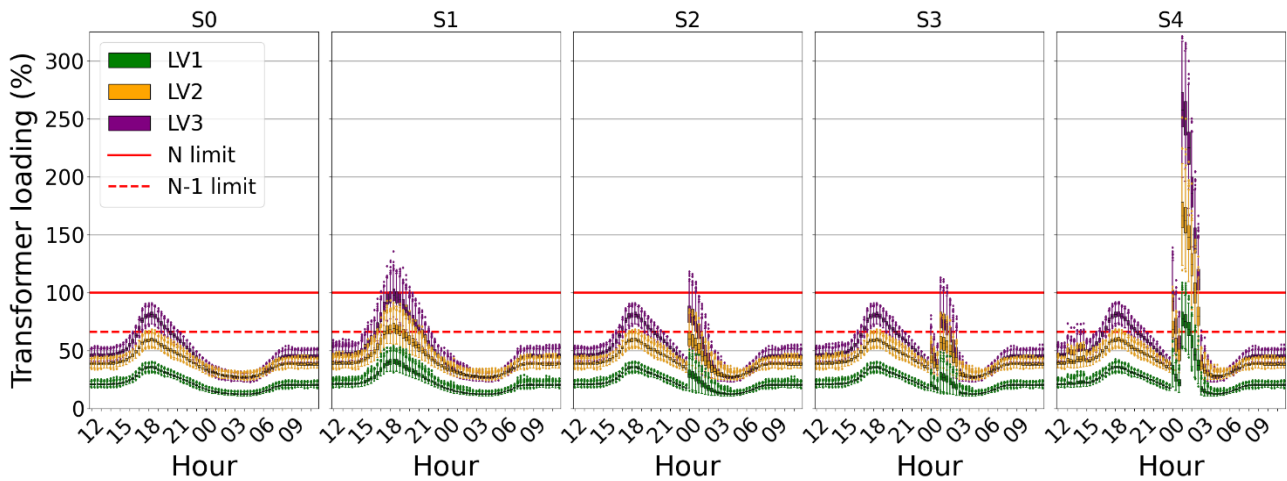

Fig. 8: Distribution of transformer loading in each charging scenario and LVDN area.

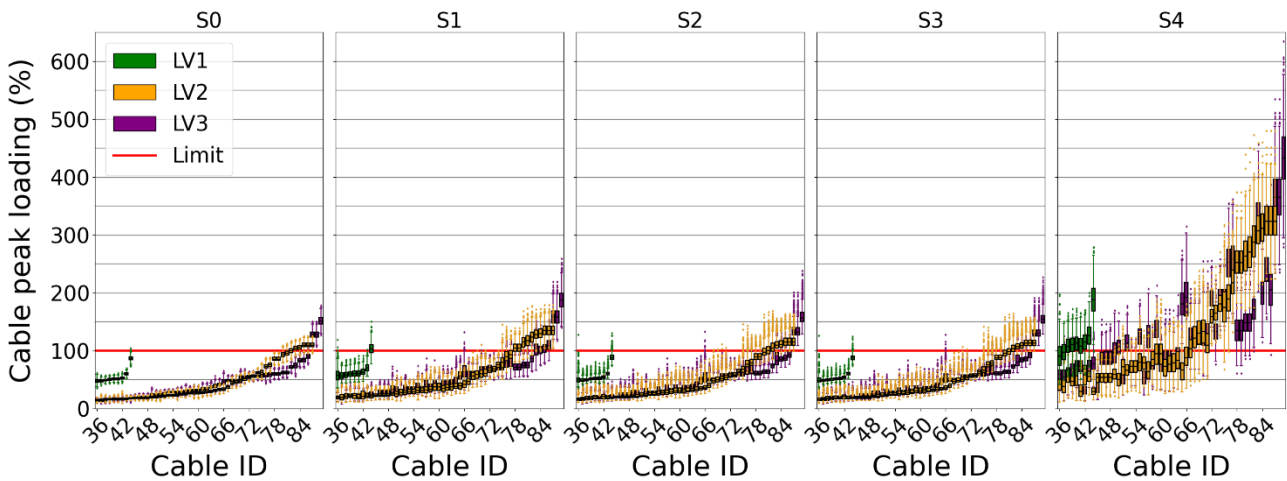

Fig. 9: Distribution of cable peak loading in each charging scenario and LVDN area.

#### 5.4.4 Main findings and recommendations

Main findings and recommendations for grid impacts:

- With respect to the increasing EV adoption, it has been shown that the LVDN is generally expected to be the most vulnerable part of the power grid. Nonetheless, the grid impact of EVs varies significantly between different areas, depending on specific conditions, which necessitates individual and detailed assessments.
- Despite the study being based on a real-world case of the urban PDN in Frederiksberg, important conclusions can be drawn. Assuming a natural charging pattern, where most EVs do not charge daily, ToU- and cost-based smart charging can temporarily alleviate the strain caused by uncontrolled charging by shifting demand to off-peak hours. However, long-term strategies and better pricing incentives are required to distribute the load and prevent the creation of larger secondary peaks.
- Crucially, the study emphasizes the importance of avoiding incentives that lead to the synchronization of charging events on a single day, which would otherwise be spread over several days. User-centric smart charging, without considering PDN constraints, where individuals with home charging access aim to pursue the cheapest rates, could lead to substantial needs for reinforcement at high societal costs and raise concerns about equity and cost-reflectiveness. Therefore, it is imperative to develop solutions that consider PDN constraints.

## 5.5 Smart charging in the city

While smart charging at home is often easily accessible, urban areas with limited home charging availability will largely depend on public and semi-public charging infrastructure. Therefore, the FUSE project aimed to test and demonstrate smart charging capabilities in the urban context. As highlighted in the previous section, certain PDN areas already face capacity constraints, hindering the deployment of new charging infrastructure. With increasing electrification, establishing new firm grid connections in a timely manner will become increasingly challenging. This will result in a growing disparity between available grid capacity and connection requests, leading to more frequent delays for new PDN connections. To address this challenge, the urban demonstration focused on accelerating the deployment of charging infrastructure through conditional connection agreements (CCAs).

### 5.5.1 Conditional connection agreements

Traditionally, grid connections have included firm access rights, allowing users to connect and utilize their full contracted capacity if available. However, as electrification increases, establishing new firm grid connections becomes more challenging due to the significant time, resources, and manpower required for grid reinforcement or extension. To address this, the concept of voluntary conditional connection agreements (CCAs) has been proposed. CCAs, also known as connections with limited grid access, variable capacity contracts, or flexible, non-firm, and interruptible connections, offer non-firm access rights that vary based on grid conditions. CCAs can be temporary, reducing connection times by allowing grid access before reinforcements are complete, or permanent, mitigating the need for extensive grid reinforcements. DSO Radius currently offers both types of products: Step-by-step full scope of delivery (Trinvis fuldt leveringsomfang) and Limited Network Access (Tilslutning med Begrænset Netadgang). However, these products are currently only offered to large customers connected to the MVDN and higher, and are not viable for small customers connected to the LVDN due to grid observability issues and costly communication and remote control requirements.

While currently limited to large customers, there is a need for CCAs in the LVDN, as illustrated in Fig. 10. Although the load lies below the technical limit of the transformer, the dimensioning limit of 66% loading is frequently exceeded, especially in winter. Load fluctuations are also evident, with peak loads in 2021 due to increased home office arrangements during the COVID-19 pandemic and decreased loads in 2023 due to the energy crises. Regarding the connection of new charging infrastructure, the historical load pattern suggests that firm connections would require transformer reinforcement. However, ample unused capacity exists due to reserved grid capacity for N-1 contingencies and seasonal and daily load variations, which could be effectively utilized through CCAs.

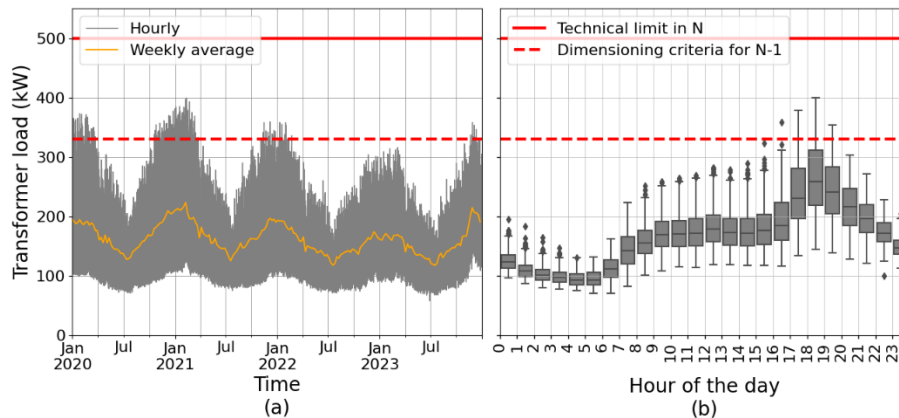

Fig. 10: Transformer load of LV3. While Subplot (a) illustrates the hourly and weekly average load from 2020 to 2023, Subplot (b) depicts the corresponding load distribution throughout one day. Assuming unity power factor for simplicity, technical and operational limits are indicated by solid and dashed red lines, respectively.

### 5.5.2 Proposed conditional connection agreement solutions

To develop CCASs for the LVDN that can be practically implemented by the DSO without significant changes to its core operations, four approaches have been devised. Fig. 11 provides an overview of each solution, which involves the same actors. Within this framework, the DSO collaborates with the customer, typically the charge point owner, to establish a CCA. The charge point owner may enter into a service agreement (SA) with a Charge Point Operator (CPO) to manage the charging infrastructure if they do not serve as the CPO themselves. The DSO provides capacity profiles to the CPO, who ensures that the charging infrastructure operates within specified power limits. Each CCA uses different data to inform capacity, leading to varying benefits and drawbacks.

**CCAS1:** The first solution utilizes historical smart meter data to inform monthly capacity profiles based on the maximum experienced load. While offering a viable short-term solution using available smart meter data, drawbacks include issues arising from changes in load patterns and suboptimal utilization of free capacity. Significant free capacity is lost due to the dimensioning criterion of 66% loading and the inability to utilize capacity differences between actual and historical maximum loads.

**CCAS2:** Aims to improve PDN utilization by granting access to reserved grid capacity, considering Denmark's rare outages and generally stable LVDN conditions. It formulates both N and N-1 power profiles using historical data, complemented by a grid status indicator to operate near the transformer's technical limit in normal operation while ensuring reduced capacity in N-1 events.

**CCAS3:** Utilizes recent smart meter data to inform capacity profiles based on short-term load forecasts. This approach offers two major advantages: better grid utilization by anticipating loads that may be lower than historical maximums and reducing potential congestion through precise forecasts. However, forecasting inaccuracies and challenges in obtaining accurate recent data, along with increased operational costs, are significant drawbacks.

**CCAS4:** Allocates available grid capacity based on high-resolution (5-minute interval) transformer load measurements. Unlike the first three solutions, which rely on hourly average smart meter data, CCAS4 captures actual load behavior, mitigating potential short-term peaks within an hour that are not accurately reflected in historical data. This approach maximizes PDN capacity utilization and handles both N-1 and congestion situations. Although it increases initial investment costs, CCAS4 has the potential to streamline the DSO's operational complexity and costs when offered as a standalone solution.

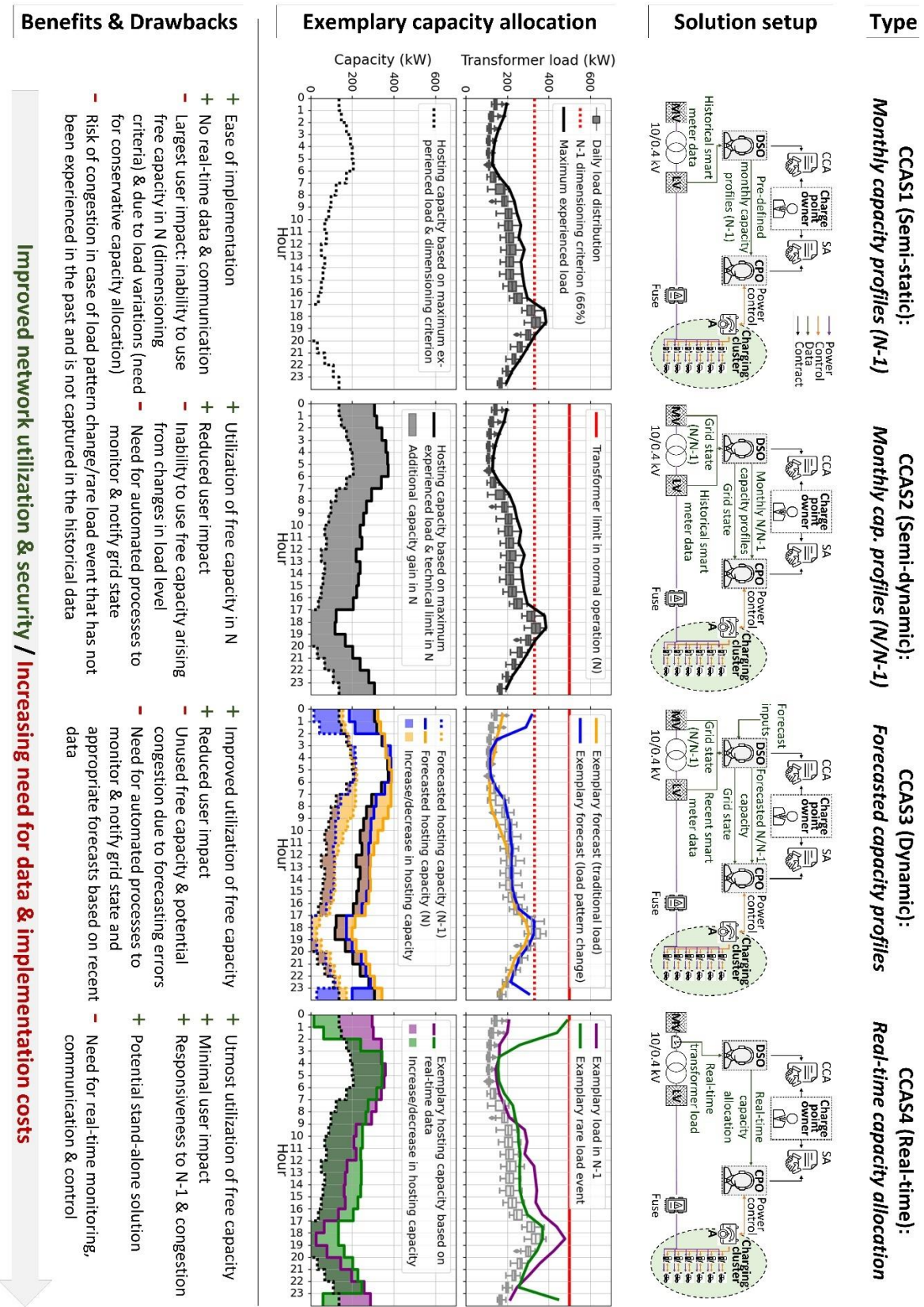

Fig. 11: Overview of the proposed CCASs. For each solution, a simplified overview of the technical and contractual setup between the main actors is provided. Furthermore, the transformer load and the resulting grid capacity are exemplified for January to highlight the benefits and drawbacks of each approach.

### 5.5.3 Demonstration setup

Fig. 12 illustrates the setup of the demonstration activities, which took place at two public curbside charging clusters in northeastern Frederiksberg. As shown in Fig. 12 (a), both clusters are equipped with six Zaptec Pro chargers sharing a single grid connection, each with a maximum capacity of 32 A. To minimize initial investment costs, the grid connection is limited to 63 A. Consequently, both charging clusters use Zaptec’s phase and load balancing. While individual charger power can be controlled, this demonstration focuses on managing power for the entire cluster based on available grid capacity inferred from the transformer load, using the Zaptec API. The selected LV3 transformer does not directly supply the two charging clusters; it was chosen due to existing capacity constraints and because much of Frederiksberg’s LV3 operates in a meshed configuration. Over two months, both CCAS1 and CCAS2 were implemented and demonstrated. Signs were placed on the chargers to inform customers about the demonstration and potential power reduction between 16:00 and 21:00, as shown in Fig. 12 (b).

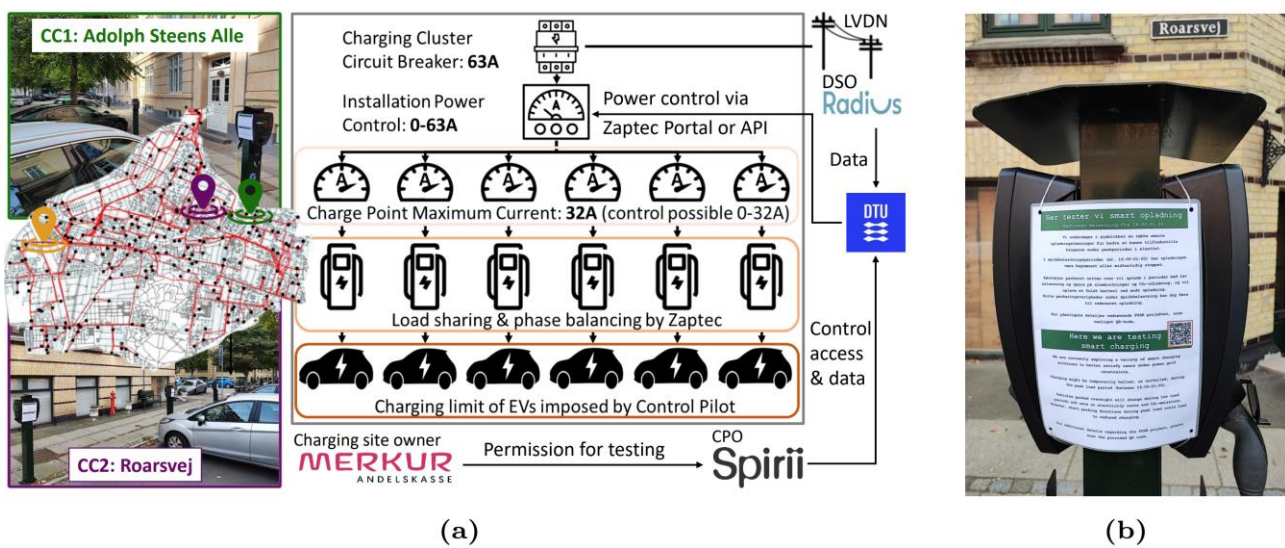

Fig. 12: Overview of the demonstration setup. Subplot (a) provides a schematic of the technical setup for each charging cluster, detailing the roles of the project partners in the demonstration. Subplot (b) shows the signage used to inform customers about the demonstration activities. The map of Frederiksberg features green, purple, and orange markers indicating the locations of CC1, CC2, and the LV3 transformer, respectively.

### 5.5.4 Demonstration results

The results of the CCAS1 demonstration, conducted over one month, are depicted in Figs. 13 and 14. Fig. 13 presents the daily power distribution at both charging clusters for the demonstration period (25.09.23 to 24.10.23), the previous month (25.08.23 to 24.09.23), and the previous year (25.08.22 to 24.08.23). Analysis of historical charging behavior indicates low utilization at both clusters, with the grid connection of approximately 43.5 kW rarely reached. Peak power demand aligns with peak grid loading, while demand decreases during the day and early night, with few charging events occurring between 03:00 and 09:00. During the CCAS1 demonstration, charging was limited between 16:00 and 21:00, as indicated by the red line. From 16:00 to 17:00, the available power was restricted to approximately 38 kW. No charging was allowed between 17:00 and 20:00, and from 20:00 to 21:00, the capacity was limited to about 33.8 kW. The results show that peak power demand between 17:00 and 20:00 was successfully suppressed. However, a rebound effect occurred once the power restriction was lifted, with increased charging demand during the late evening and early night hours. This rebound effect remained within acceptable grid limits as defined by the CCA. Similar to historical data, most charging events terminated before 03:00, with minimal utilization during nighttime hours.

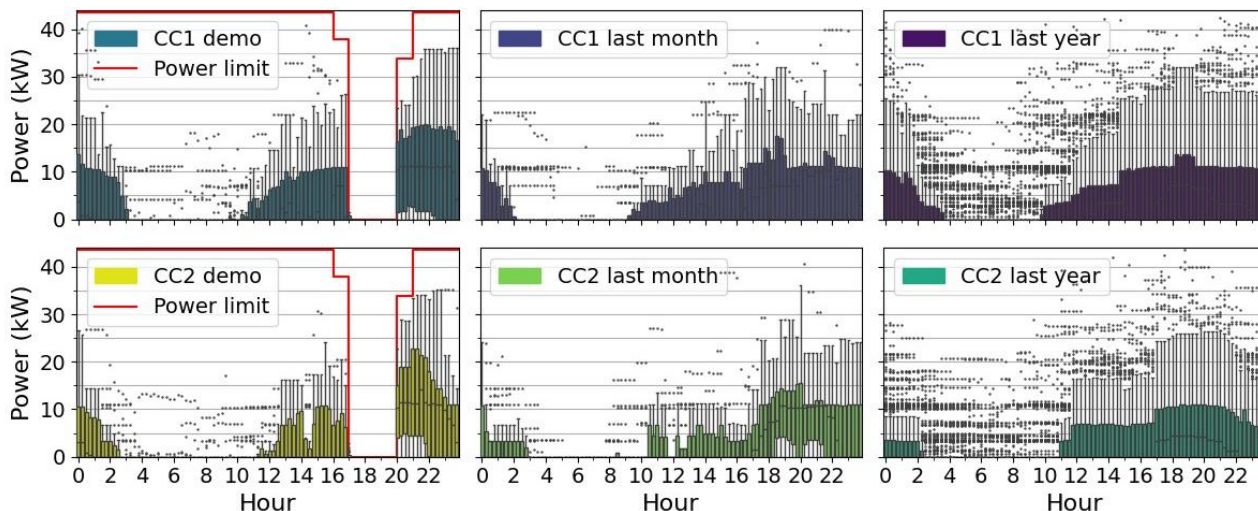

Fig. 13: Daily power distribution at CC1 (top) and CC2 (bottom) derived from CCAS1 demo (left), the previous month (center), and one year (right).

Fig. 14 analyzes the impact of CCAS1 on customers due to the three-hour charging prohibition. Approximately 20% of charging events at both clusters were negatively affected. Unserved demand, where EVs arrived and departed during the power restriction without charging, was less than 9%. Up to 11% of events experienced reduced energy delivery due to delayed or interrupted charging, causing EVs to leave before completion. The remaining events were unaffected. About 53% of charging events at CC1 occurred outside the restriction period, while CC2 saw more events during peak hours. Approximately 42% of CC2 events were flexible, with EVs plugged in long enough (e.g., overnight) to be fully charged after the restriction was lifted, compared to roughly 25% at CC1. Comparing the demonstration results with simulations from the previous month and year, the impact closely mirrors historical charging behavior, indicating that the signs informing customers about the demonstration did not significantly alter charging habits. Interestingly, the demonstration showed a larger share of unserved events and a smaller share of partially served events compared to the simulated impact on past data.

Finally, demonstration results of CCAS2 are illustrated in Fig. 15. The results are presented for the entire three-week period, with selected days shown in greater detail. N-1 events were randomly generated, resulting in variations in timing and duration for each event. Unlike CCAS1, which adjusts power hourly, CCAS2 dynamically adapts power based on grid state and power profiles, demonstrating its ability to respond quickly to sudden changes in available power. Three different scenarios are depicted. In the first scenario, a simulated N-1 event occurred between 17:00 and 20:00, resulting in power being restricted to zero for the duration of the event (e.g., on 11.11.23). In the second scenario, an N-1 event ended after 20:00. Here, power increased at 20:00 according to the N-1 power profile, with full power restored either at the event's conclusion before 21:00 or at 21:00 as dictated by the power profile (e.g., on 25.10.23). In the third scenario, an N-1 event began between 16:00 and 17:00, leading to a power reduction to roughly 38 kW. Power was further reduced to zero at 17:00 until the N-1 event concluded (e.g., on 30.10.23). The plots indicate that EVs successfully paused charging or, if they arrived at the charging clusters during peak hours, only began charging after the power restriction was lifted.

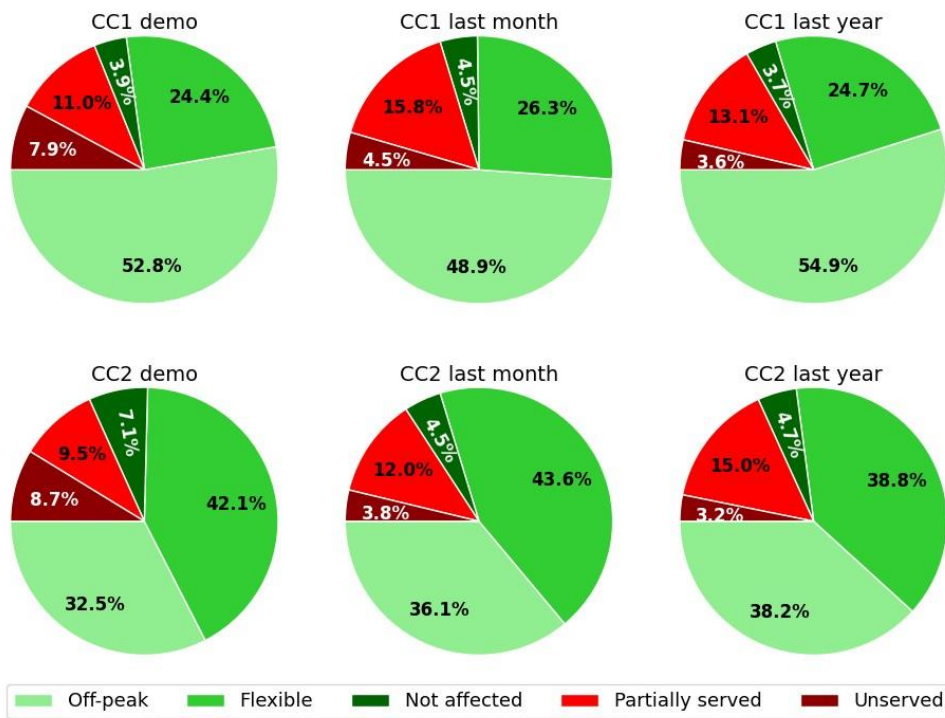

Fig. 14: Customer impact of CCAS1. The demo results are shown on the left, while the center and right plots depict the simulated impact for the previous month and year. Charging events are categorized as impacted (red) or not impacted (green) and are further split into different subcategories. Impacted EVs 1) did not charge (dark red) or 2) received less energy (red). Not impacted EVs 1) charged outside (light green) of the power restriction, 2) were affected by the charging restriction but stayed long enough at the charging cluster to complete charging (green), or 3) were connected but did not charge during the restriction, i.e., finished or delayed charging (dark green).

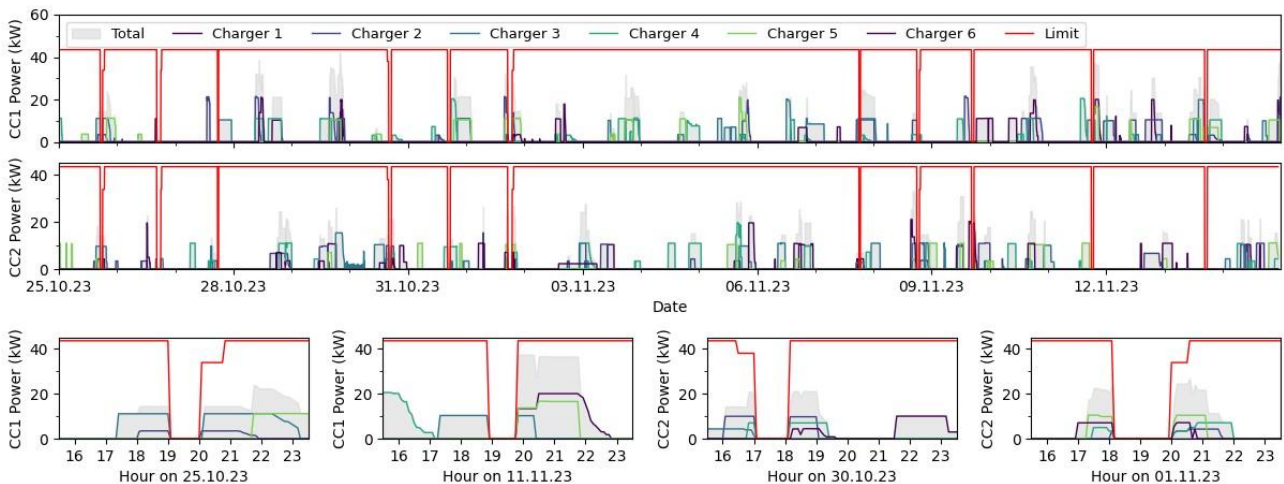

Fig. 15: Demonstration results of CCAS2. The top two plots illustrate the charging behavior at CC1 and CC2 during the three-week demonstration. The four plots below provide a detailed view of selected days, highlighting the adherence of the charging clusters to sudden changes in available grid capacity triggered by simulated N-1 events.

### 5.5.5 Main findings and recommendations

Main findings and recommendations for “Smart charging in the city”

- The proposed CCASs offer a potential short-term solution for accelerating the deployment of new grid connections. While the FUSE project demonstrated that the power of urban public charging clusters can be controlled according to the available grid connection, these solutions are also applicable to other flexible consumers. Although CCAs have so far been used infrequently and primarily for large customers connected to the MVDN, they should also be offered to customers in the LVDN. Particularly on a temporary basis, CCAs offer high potential to accelerate electrification and enable DSOs to make better-informed decisions about potential investments. Grid customers benefit from reduced connection times and costs, while society as a whole would benefit from reduced PDN tariffs due to higher grid utilization and the potential deferral of PDN reinforcements.
- Each solution offers different benefits and drawbacks and thus needs to be assessed on a case-by-case basis depending on the given conditions. CCAS1 offers a readily implementable solution as it solely utilizes data already accessible to the DSO. However, it cannot take advantage of the reserved N-1 grid capacity and requires regular reevaluation to accommodate possible changes in load patterns. CCAS2 seeks to harness the reserved grid capacity but necessitates the communication of the grid state. Although feasible for limited deployment, widespread implementation would demand automated processes, necessitating investment in establishing such infrastructure. CCAS3 targets the use of short-term forecasts to utilize the free capacity arising from fluctuations in load levels. This solution requires access to recent data and forecasting capabilities, which currently presents a barrier to implementation. Finally, CCAS4 is the most promising solution for optimal utilization of available PDN capacity. It proposes a solution based on real-time transformer load measurements and simplifies operational complexity for the DSO, as the allocation of power is straightforward and does not rely on intricate grid status monitoring and forecasting. Although encompassing higher investment costs, the installation of transformer load monitoring provides the additional advantage of increased grid observability.
- With respect to customer satisfaction, it was shown that even with significant power restrictions in the winter months (i.e., January), less than 20% of customers were negatively impacted. Over the course of one year, this impact would decline significantly as transformer loading decreases during summer, allowing full power provision. To further decrease customer dissatisfaction, prioritized charging should be explored, wherein available power during peak hours is exclusively allocated to sessions requiring priority charging.

## 5.6 A sustainable charging experience

While smart charging can be used to accelerate charging infrastructure deployment by controlling charging according to PDN constraints, smart charging could also play a fundamental role in reducing carbon emissions of cities. Within the project, the latter was assessed by Electricity Maps for the municipality of Frederiksberg, based on data collected from two charging clusters (CC1 and TEC Frederiksberg), totaling more than 1,700 charging events. Total emissions resulting from the charging were quantified and compared to emissions from ICE cars that would have burned an equivalent amount of fuel. Additionally, emissions when optimizing charging were quantified, providing an actionable pathway to further reduce EV emissions.

There are two main methods to calculate the carbon intensity of electricity consumption: average and marginal. The average carbon intensity considers the emissions from the entire mix of consumed electricity, while the marginal carbon intensity identifies the emissions from the power plant supplying the additional electricity needed at a specific time. For this study, the average carbon intensity was chosen because EV charging profiles represent long-term, systematic decisions that short-term marginal carbon intensities do not accurately reflect. Additionally, Scope 2 emissions are better aligned with average carbon intensity calculations.

### 5.6.1 Quantification of emission savings from EVs

To achieve Frederiksberg's goal of becoming net-zero by 2050, it is crucial to ensure that replacing ICE vehicles with EVs significantly reduces the city's total emissions. A simple comparison method, based on typical efficiencies of EVs and ICE cars, was used to translate electricity charged into an equivalent amount of fuel. As outlined on Fig. 16, following this methodology, 1 kWh of charged electricity in an EV translates into roughly 0.51 l of petrol. The translation from amount of energy charged to total emissions relies on the following emission factors. Burning one liter of petrol equates to the release of 2.3 kgCO<sub>2</sub>eq in the atmosphere, while the charge of 1 kWh amounts to releasing 133.54 gCO<sub>2</sub>eq in 2021 and 96.61 gCO<sub>2</sub>eq in 2022.

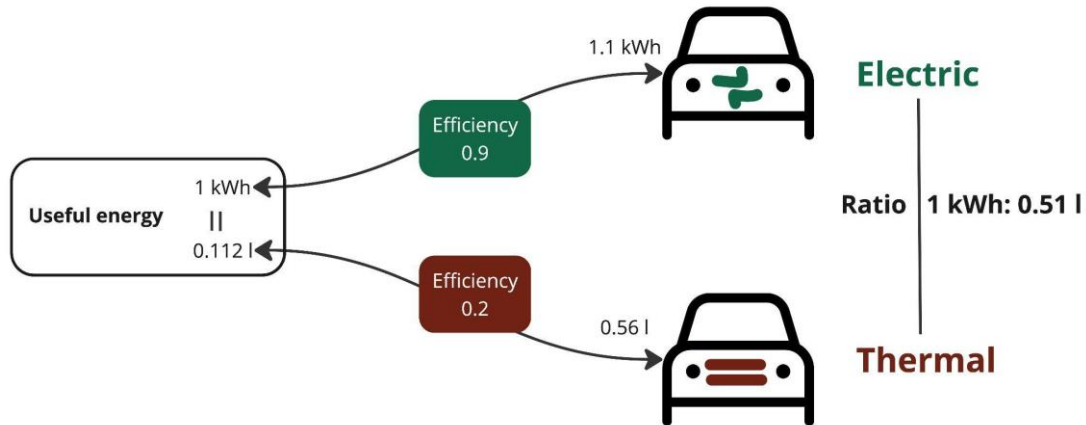

Fig. 16: Equivalence between energy charged for EVs and fuel for ICEs.

The left bars in Fig. 17 demonstrate that direct emissions for EVs calculated from the above mentioned dataset of charging events (2.7 tCO<sub>2</sub>eq) is an order of magnitude ten lower than for an equivalent usage of petrol cars (31 tCO<sub>2</sub>eq). This confirms that the electrification of transportation is a powerful mechanism for the city of Frederiksberg to quickly reduce its total emissions, especially considering that the average carbon intensity of the electricity on the Eastern Danish grid has decreased by 55% since 2018, and is projected to more than half by 2025.

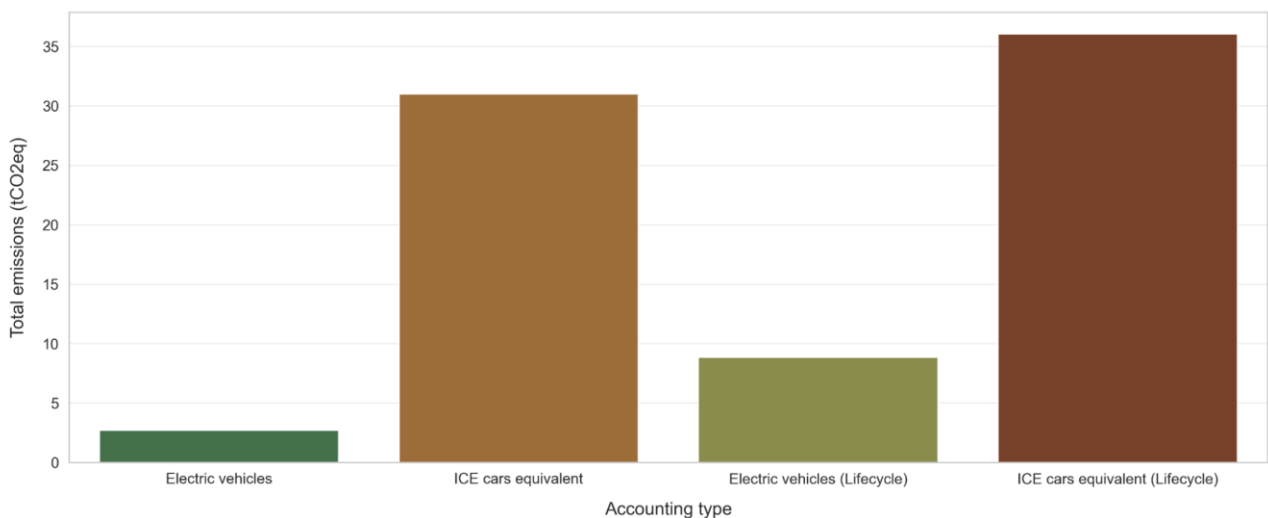

Fig. 17: Comparison of emissions from charging EVs in the dataset to equivalent usage with ICE cars for both direct (left) and lifecycle emissions (right).

While direct emissions from EVs are much lower than those from their ICE counterparts, it is crucial to ensure that lifecycle emissions are also reduced. Recommending electrification based solely on direct emissions would lead to an export of emissions, which, while improving local metrics (e.g., for Frederiksberg), would not contribute to a viable global decarbonization strategy. Based on the emission intensities from Climobil for EVs and ICE cars, as shown in Tab. 3, and considering that a typical EV consumes 0.198 kWh/km and an ICE car 0.08 l/km, total upstream emissions were calculated.

Tab. 3: Decomposition of upstream emissions for both car types.

	Glider	Engine/Motor	Tank	Maintenance	Battery	Total upstream
ICE car (gCO <sub>2</sub> eq/km)	21	2	1	6	0	30
EV (gCO <sub>2</sub> eq/km)	22	6	0	6	11.9	45.9

Fig. 17 compares the total emissions for both types of vehicles, including lifecycle emissions (rightmost bars). Although upstream emissions for EVs are higher (6.13 tCO<sub>2</sub>eq vs 5.05 tCO<sub>2</sub>eq), the total emissions for EVs are much lower overall (8.86 tCO<sub>2</sub>eq vs 36 tCO<sub>2</sub>eq). This confirms that even if a significant portion of the emissions is exported, the electrification of transportation will still result in an overall decrease in total global emissions.

### 5.6.1.1 Emission savings from smart charging

As highlighted in Fig. 18, the direct carbon intensity of electricity of the Danish grid can vary by a factor of at least 2 within a single day. These fluctuations result in a difference of up to 48 gCO<sub>2</sub>eq/kWh between the actual hourly carbon intensity and the yearly average, representing a 30% deviation. Therefore, emissions from charging events occurring throughout the day and night will be inaccurately quantified if calculated using an average yearly emission factor. Charges that occur during peak carbon intensity periods will have a significantly higher impact than those that take place during off-peak times when carbon intensity is lowest. When using hourly instead of yearly average carbon intensities, the total emission footprint of the considered charging events drops from 2.7 to 2.4 tCO<sub>2</sub>eq (-11%) by accounting more accurately for emissions. The benefits of using hourly carbon accounting would therefore be manifold for Frederiksberg. Adopting a more accurate methodology would strengthen the credibility of accounting and hedge their approach against future evolutions of recommended carbon accounting practices. It would also empower charging optimization to further minimize the carbon footprint. Providing incentives to users to charge their EVs when the carbon intensity of the electricity is the lowest would reduce the total emissions of charges. Typically, on the day represented in Fig. 18, that would mean encouraging charging during the early hours of the morning, or late hours of the evening.

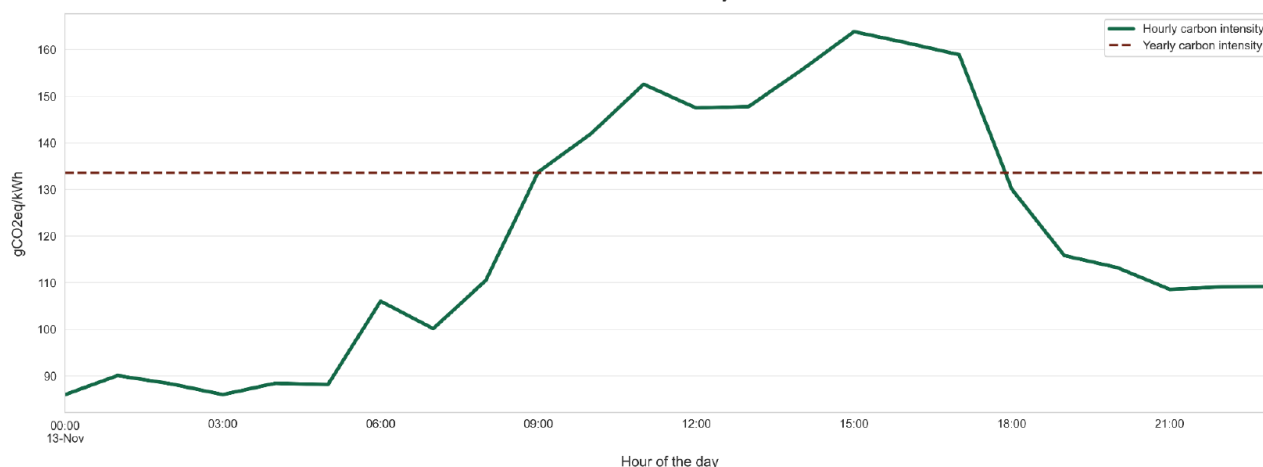

Fig. 18: Comparison of the yearly and hourly direct carbon intensity in Eastern Denmark on 13.11.2021.

To determine the upper bound for the savings potential offered by smart charging, it was assumed that the charge is flexible and can be controlled while fulfilled the initial energy demand recorded in the data. Fig. 19 compares the total emissions from EV charging with and without the adoption of smart charging. The potential benefits of smart charging is obvious; the computed emissions drop from 1.491 to 1.25 tCO<sub>2</sub>eq, which represents a 16% decrease. When only optimizing events that start after 17:00, to avoid a decrease in charging infrastructure efficiency as highlighted in Section 5.2.2, the potential emission savings are even greater. The total footprint decreases from 0.37 tCO<sub>2</sub>eq to 0.30 tCO<sub>2</sub>eq with smart charging, which is a 19% decrease.

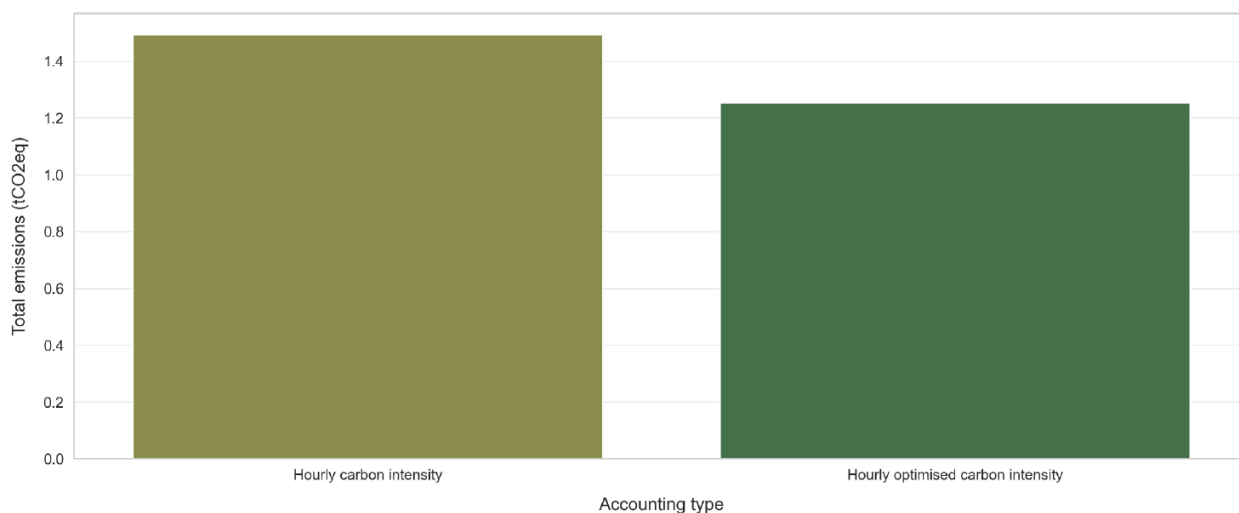

Fig. 19: Comparison of total EV emissions from hourly carbon intensities with and without smart charging.

### 5.6.1.2 Main findings

Throughout this study, the charging dataset has served as a valuable reference for quantifying greenhouse gas emissions from transportation within the municipality of Frederiksberg. As highlighted in Fig. 20, this dataset provides a path for reducing carbon emissions from transportation, which is essential for the city to achieve its net-zero objective by 2050. Initially, it was observed that the electrification of transportation within the city could reduce direct emissions by a factor of 10. The study also demonstrated the importance of using hourly carbon intensities, which correct an 11% overestimation of total emissions. Furthermore, the study suggests that access to granular electricity data, can enable additional emission savings through smart charging procedures, achieving savings of 16-19%. Beyond emission savings, smart charging offers further benefits, such as reduced charging costs for EV owners, given the strong correlation between day-ahead electricity prices and carbon intensity (approximately 0.7 in 2023 in Eastern Denmark).

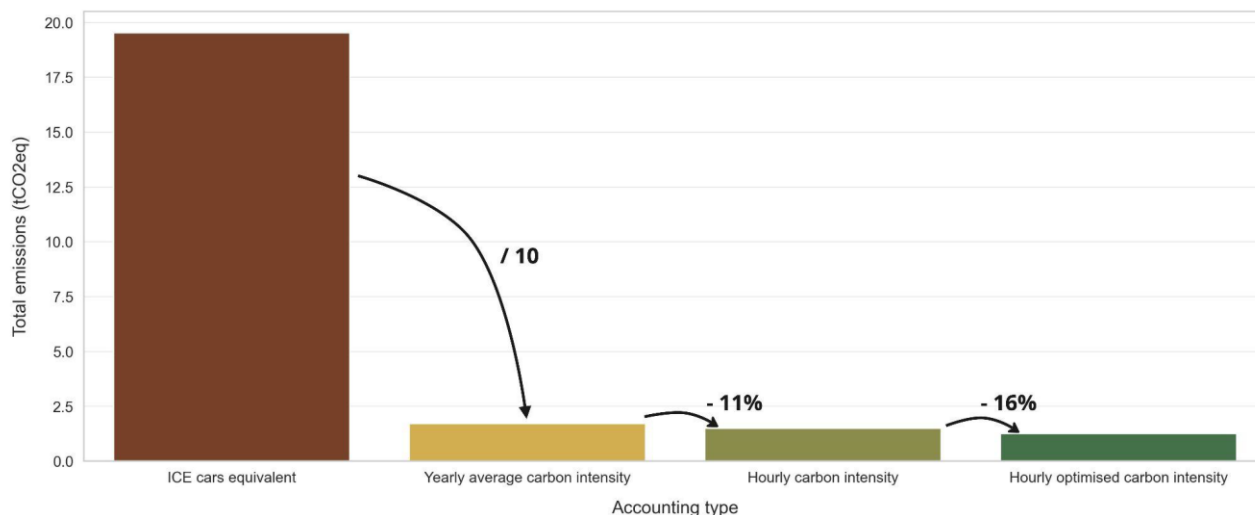

Fig. 20: Comparison of the total emissions footprint for all considered scenarios.

## 6. Utilisation of project results

The project outcomes, in terms of learning and results, are being utilized by the consortium partners in their continued work with urban charging infrastructure.

The learnings regarding charging infrastructure sufficiency are being used by the municipality of Frederiksberg in their own EV strategy, as well as by Danish e-mobility and COWI in their consultancy services provided to other cities in Denmark.

Technical results from demonstrations are being utilized by SPIRII, Electricity Maps, and Radius in their efforts to support and implement smart charging. This is aimed at minimizing charging costs, reducing emissions, and addressing grid capacity constraints through conditional connection agreements.

Elbilsforeningen has gained insights into EV users' requirements for urban charging infrastructure and user feedback from conducting smart charging using public chargers.

DTU Management and DTU Wind have already built on the project results in several new national and international research projects.

The project has resulted in 16 student projects (Bachelor's projects, Master's projects, and special courses) and has supported a total of three PhD studies.

As a visual tool for planning the types of charging infrastructure available to a city, the charging pyramid was developed (see Fig. 21). It indicates the relative volume and prioritization for different types of infrastructure. It is important to note, however, that all types of infrastructure in the pyramid play a role in dense urban centers. Infrastructure shown at the top of the pyramid, though less convenient and more expensive to establish than other types, may still be essential to meet overall demand.

## The Charging Pyramid – charging private vehicles in the city

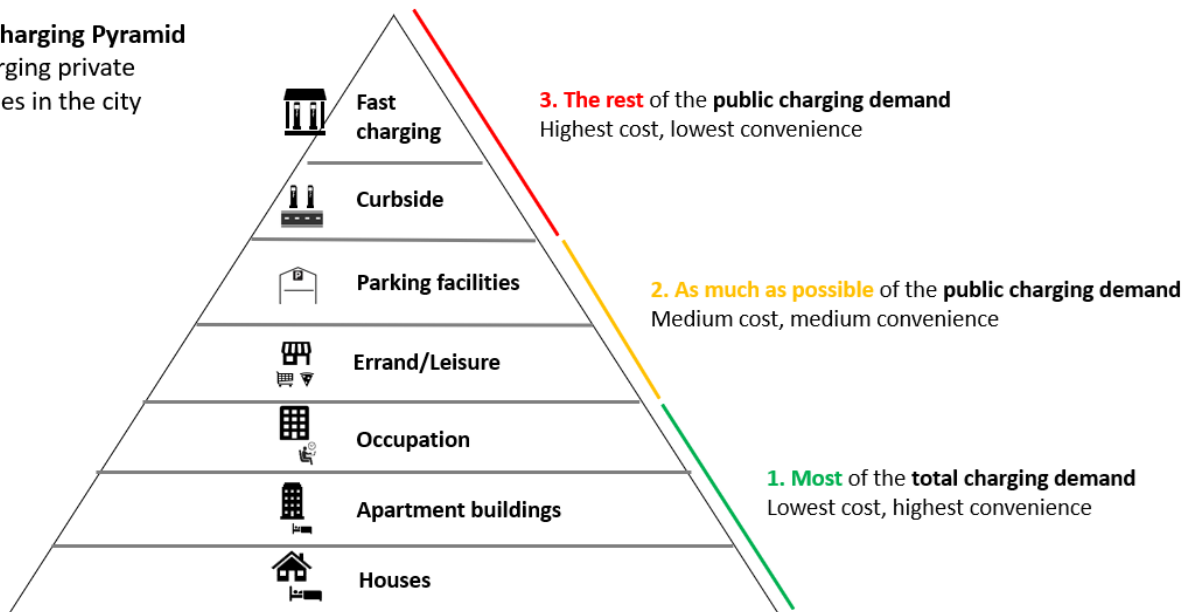

Fig. 21: The charging pyramid: types of charging infrastructures in the city.

## 7. Commercial outcomes

In the following we describe the projects commercial outcomes relating to the projects two main commercial objectives: (1) the development of charging service, led by SPIRII, and the development of knowledge and tools to guide urban charging infrastructure investments led by COWI.

### Charging service

Key results from Work Package 4 in the context of Spirii include the successful integration of the CO<sub>2</sub>-optimized charging profile into the SPIRII GO App, allowing end users to plan their charging sessions accordingly. This crucial step enables the visualization and quantification of the carbon signal's impact on emissions, offering valuable insights into CO<sub>2</sub> reduction, which the customer can choose to base their charging on. As concluded in Section 5.6.1.2, charging when electricity has a low CO<sub>2</sub> content has a significant impact on reducing overall emissions by 16-19%. However, it is not possible to quantify precisely whether the consumer has utilized this CO<sub>2</sub>-optimized charging profile, making it impossible to determine the exact CO<sub>2</sub> savings based on Smart Charging. Nonetheless, based on the hourly CO<sub>2</sub>-eq intensity in electricity with the consumed power per charging session, the total CO<sub>2</sub>-eq emissions are calculated and stored in the Spirii database. From this, an estimation of how much CO<sub>2</sub> has been saved, if the same amount of energy had been consumed by an ICE vehicle, shows a reduction of 98,237 tCO<sub>2</sub>-eq for the entire consumption through Spirii-operated chargers in 2023. This number will increase with the growth of the Spirii customer base; however, it does not directly reflect the Smart Charging reduction in CO<sub>2</sub> emissions.

A new tariff model, corresponding to Tariff Model 3.0, has also been implemented on Spirii's platform. This allows Charge Point Operators (CPOs) to adjust prices for end users in line with electricity prices, including peak periods.

Although we do not have a direct measure of the revenue generated from this new feature, it has undoubtedly contributed to Spirii's overall performance and has attracted new customers. While this commercialization directly improves Spirii's performance, it also enhances the platform's appeal to customers, ultimately leading to partner-based investments in charging infrastructure. Revenue based on new hardware charging infrastructure is expected to surpass 300 million DKK by 2025. Moreover, this project has sparked interest in developing more advanced smart charging solutions, which has strengthened the robustness of Spirii's backend, particularly in terms of Demand Response and Smart Charging, which is highly valuable.

Furthermore, WP3 tested the use of Zaptec Pro charging hardware, showing through testing that it is possible to react fast enough to signals to comply with the requirements of the FCR market. This will have a major impact on future commercial revenue streams for Spirii, where the expected revenue for ancillary services on Spirii-operated chargers is projected to exceed 3 million DKK in 2025.

Since the project started in 2019, the number of full-time employees (FTEs) in Spirii has increased dramatically, and as of September 2024, there are 130 employees across 30 different nationalities. However, it is not possible to quantify how the FUSE project has directly influenced new hires. Nonetheless, as energy management and demand response become a more substantial part of Spirii's revenue streams, more research and development in the field has become very important and has already, by 2024, led to at least 20 new hires in Spirii.

### Urban charging infrastructure investments

Knowledge building provides the basis for the consulting partners and their ability to provide high quality, evidence-based advice to many different types of clients. Getting insights from the research, demonstrations and concrete analytical results from FUSE have provided valuable insights. Through the participation in FUSE, COWI has obtained a competitive advantage when bidding for consulting services. This has led to several

consulting projects, where the involvement in FUSE has been a deciding factor. Moreover, insights related to especially assessing the demand for charging infrastructure in urban settings has been used. The charge-point calculator forms the basis for our advice. It has moreover been used by many individual stakeholders in municipalities and other organisations. We have further developed our methodologies based on the tool with adaptations to the more recent forecasts made on electric vehicle penetration in the Danish car market. Moreover, the findings from the other parts of FUSE have led to updates in some of the key parameters of this model. We are currently using this insight, and the GAIA model developed as part of FUSE in a specific project for the City of Copenhagen. Our involvement in FUSE was the reason we were chosen for this specific project.

## 8. Dissemination efforts in the project

The project has been disseminated through

general channels, through academic papers and through student projects.

### General dissemination

The project has been disseminated through its webpage, news letters as well as a number of seminars – including two seminars done in conjunction with the related ACDC project as well as the project's main end seminar held in Frederiksberg.

In addition the project has been presented numerous times in connection with DTU events and workshops towards an external audience.

Press initiatives / releases:

- Project kickoff - press release
- Chargepoint calculator - announcement at DEM annual meeting with folders and using news letters
- Radius grid impact study - article and press release
- Project end seminar - press release



FUSE end seminar - Frederiksberg

**Scientific dissemination and student projects**

A total of 17 peer-reviewed scientific publications have been carried out as part of the FUSE project – of these 11 have been published as Journal papers – and 6 at conferences and included in the associated proceedings.

This fulfills the project's original aim of 15+ scientific publications.

Further, a total of 16 student projects have been carried out in FUSE, spanning from special courses to bachelor and master projects. All this project work has been documented in student reports that adds to the scientific dissemination of the project.

See chapter 10. References for a full list of publications and student projects – as well as student and PhD projects.

## 9. Project conclusion and perspective

Despite challenges with partner substitutions and delays in carrying out demonstrations, the project initiatives have successfully supported the original objective of contributing to the acceleration of a sufficient and smart charging infrastructure roll-out in urban areas, as highlighted in Fig. 22.

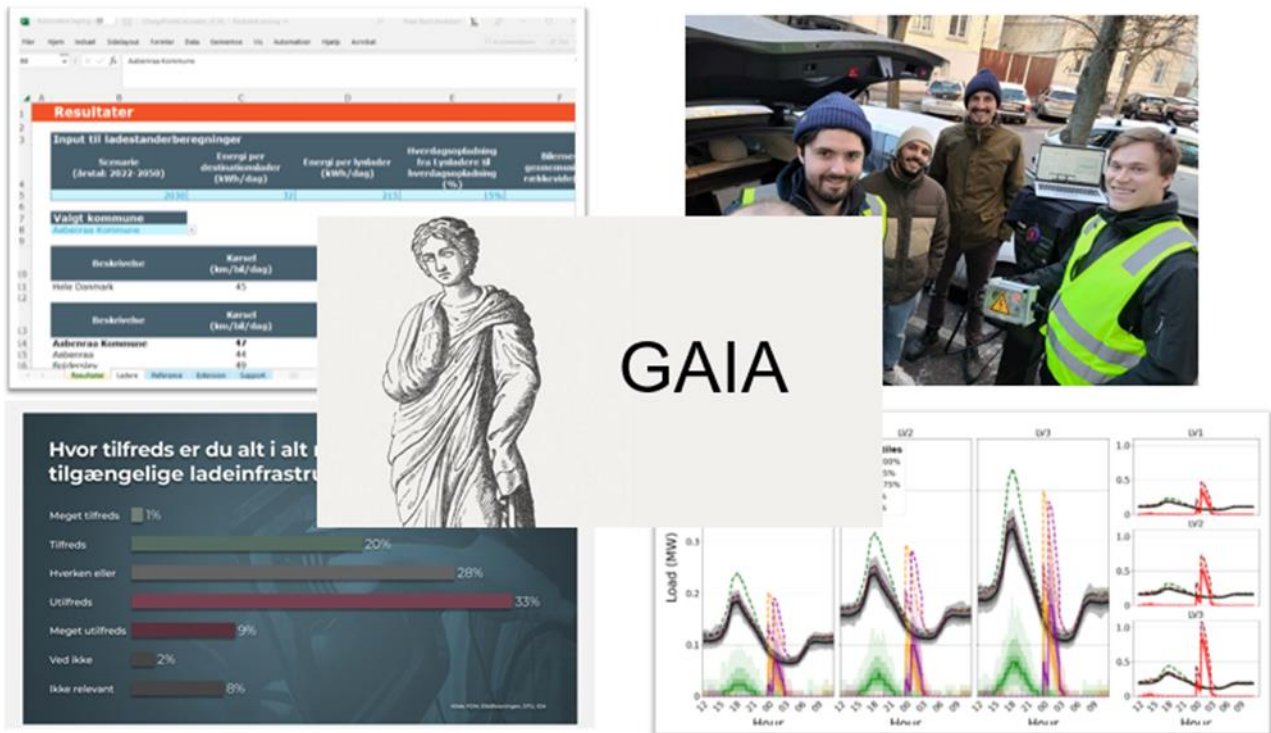

Fig. 22: Selected project results at a glance: top left - Charge Point Calculator Tool; top right - Demonstrations in Frederiksberg; middle - The GAIA Model used to forecast demand for charging infrastructure; bottom left - Large Charging Infrastructure Survey; bottom right - Grid Impact Studies in Frederiksberg.

**Charging Infrastructure Sufficiency:** The charging infrastructure in Frederiksberg is currently well-suited to meet today's demand. However, for the future, the infrastructure must be continuously developed, adding more fast charging options to achieve a balance between different types of charging infrastructure to meet future demand.

**Key Subconclusions:**

- Electric vehicle charging may potentially become a challenge for EV owners in dense urban areas. However, the overall impact is found to be relatively minimal if the charging infrastructure is developed at an appropriate pace.
- Parking restrictions affect the utilization of slow chargers and need to balance charging needs and utilization rates. According to analyses performed through the projects GAIA Model - a three-hour parking restriction during the day seems to strike this balance.
- There are certain areas in the center of Frederiksberg that the GAIA model forecasts will have the highest charging demand. The infrastructure should be expanded accordingly as to service this demand.

- Fast chargers can provide eight times higher utilization compared to slow chargers and better meet peak demand. Furthermore, fast chargers don't have to be located as close to demand as slow chargers and can therefore serve a larger area.
- Fast chargers should be organized in clusters of at least 4 outlets, ideally 10-12 outlets.
- Current wait times in Frederiksberg are minimal, and the supply exceeds demand most of the time. More fast charging will be needed in the coming years to maintain the current service level.

**Smart Charging Infrastructure:** Charging management can provide value to the grid. This is true even for urban curbside charging infrastructure, where charging flexibility exists from early evening and throughout the night. The most immediate incentives may be lowering the cost of charging and reducing emissions by optimizing the time intervals in which the car is charged. However, this comes with challenges as the increased simultaneity of charging (many cars charging according to similar objectives) may challenge the capacity of the distribution grid. Instead, incentives and products must include grid constraints in the charging management of EVs. Such schemes have been described, developed, and tested in this project.

### Key Subconclusions:

- The medium voltage grid seems largely resilient to EV adoption in the upcoming years, with transformer overloading being the only potential concern.
- The low voltage grid is generally more vulnerable, with potential for cable and transformer overloading, but the ultimate impact is highly dependent on specific local grid conditions.
- Cost-based charging is beneficial in the short term as it separates EV charging from the conventional evening peak.
- Charging schemes for emission savings have been demonstrated and their potential for emissions reduction quantified.
- However, with more EVs and more closely coordinated charging, new peaks may form that challenge the distribution grid, especially if charging is synchronized to the same days and times.
- Conditional connection agreements represent a pragmatic and practical way to efficiently use the available grid capacity at a site used for public charging, offering the potential to accelerate electrification.
- Conditional connection can be implemented in different variants depending on its reliance on either historic or near-real-time data. This represents a trade-off between grid utilization, complexity, and costs. The more advanced types may serve as a bridge to future solutions, including market-based approaches.
- Conditional connections have been successfully demonstrated in Frederiksberg in simpler implementations. More implementations will be tested in other projects based on the work done in FUSE.

An overarching conclusion from the project is that with careful attention to the development of the charging infrastructure, it will be both possible and practical for inhabitants in the urban centers of Denmark to own EVs.

The project has pointed to specific initiatives that may serve the goal of sufficient and smart charging infrastructure.

### Recommendations:

- Continue developing conditional capacity contracts using real-time data. This work is being continued in the Horizon Europe FLOW project and the Danish ELFORSK e2flex project.
- Besides developing the contracts to become more advanced, it is also possible to scale up the demonstrations to cover more charging clusters in a larger geographical area.

- Use project findings to further develop the Municipality of Frederiksberg's EV strategy, as well as those of other municipalities with high population density.
- Continue developing the charge point calculator as a free and open tool for municipalities starting with charging infrastructure planning.
- Develop new tools that allow municipalities, grid companies, and charge point operators to more easily coordinate charger planning and placement as part of the tendering process. Project partner Radius has already published a tool providing insights into local grid capacity, which can be very helpful for infrastructure planning.
- The project has shown that curbside parking smart charging is technically possible and can provide value. It is essential to involve users more closely, allowing them to opt in or out of the charging management based on their time and willingness to participate.
- The GAIA demand model can be developed to cover more cities. It already covers large parts of Copenhagen and can, therefore, be used outside Frederiksberg.

## 10. References

### PhD projects connected to the project

- [P1] Tim Unterluggauer, "Urban Electric Vehicle Charging Infrastructure - Grid Impacts and Services", Mar 2021 – Feb 2024 (supervisors: P.B. Andersen, J. Rich, M. Marinelli) <https://orbit.dtu.dk/en/persons/tim-unterluggauer>
- [P2] Simone Striani, "Electric vehicle clustering methods for behind the meter services", (co-funded with FUSE), Jul 2021 – Jun 2024 (supervisors: M. Marinelli, P.B. Andersen, J. Engelhardt) <https://orbit.dtu.dk/en/persons/simone-striani>
- [P3] Kristian Sevdari, "Control and clustering of autonomous electric vehicle chargers", (co-funded with FUSE), Dec 2020 – Nov 2023 (supervisors: M. Marinelli, P.B. Andersen) <https://orbit.dtu.dk/en/persons/kristian-sevdari>

### Journal papers

- [J1] T. Unterluggauer, J. Rich, P.B. Andersen, and S. Hashemi (2022). "Electric vehicle charging infrastructure planning for integrated transportation and power distribution networks: A review." *eTransportation*, 12, 100163, <https://doi.org/10.1016/j.etrans.2022.100163>.
- [J2] T. Unterluggauer, F. Hipolito, S. Klyapovskiy, and P.B. Andersen (2022). "Impact of Electric Vehicle Charging Synchronization on the Urban Medium Voltage Power Distribution Network of Frederiksberg." *World Electric Vehicle Journal*, 13(10), 182, <https://doi.org/10.3390/wevj13100182>.
- [J3] T. Unterluggauer, F. Hipolito, J. Rich, M. Marinelli, and P.B. Andersen (2023). "Impact of Cost-based Smart Electric Vehicle Charging on Urban Low Voltage Power Distribution Networks." *Sustainable Energy, Grids and Networks*, 35, 101085, <https://doi.org/10.1016/j.segan.2023.101085>.
- [J4] T. Unterluggauer, F. Hipolito, P.B. Andersen, J. Rich, and M. Marinelli (2024). "Conditional Connection Agreements for EV Charging: Review, Design, and Implementation of Solutions." Under review. Available at SSRN: <https://dx.doi.org/10.2139/ssrn.4734703>.
- [J5] F. Hipolito, C.A. Vandet, J. Rich (2022). "Charging, steady state SoC and energy storage distributions for EV fleets." *Applied Energy*, 317, 119065, <https://doi.org/10.1016/j.apenergy.2022.119065>.

- [J6] F. Hipolito, J. Rich, and P.B. Andersen (2024). "The role of EV fast charging in the urban context: An agent-based model approach". Under review. Available at SSRN: <http://dx.doi.org/10.2139/ssrn.4658638>.
- [J7] A. Thingvad, P.B. Andersen, T. Unterluggauer, C. Træholt, M. Marinelli (2021). "Electrification of personal vehicle travels in cities-Quantifying the public charging demand." *eTransportation*, 9, 100125, <https://doi.org/10.1016/j.etrans.2021.100125>.
- [J8] S. Striani, T. Unterluggauer, M. Marinelli, and P.B. Andersen. "Electric Vehicle Charging Cluster: A Set of Flexibility Indexes." Under review. Available at SSRN: <https://dx.doi.org/10.2139/ssrn.4604986>.
- [J9] K. Sevdari, L. Calearo, B. H. Bakken, P. B. Andersen, and M. Marinelli (2023), "Experimental validation of onboard electric vehicle chargers to improve the efficiency of smart charging operation." *Sustainable Energy Technologies and Assessments*, 60, 103512, <https://doi.org/10.1016/j.seta.2023.103512>.
- [J10] K. Sevdari, L. Calearo, P. B. Andersen, and M. Marinelli (2023), "Ancillary services and electric vehicles: An overview from charging clusters and chargers technology perspectives." *Renewable and Sustainable Energy Reviews*, 167, 112666, <https://doi.org/10.1016/j.rser.2022.112666>.
- [J11] K. A. Vandet, J. Rich (2023), "Optimal placement and sizing of charging infrastructure for EVs under information-sharing." *Technological Forecasting and Social Change*, 187, 122205, <https://doi.org/10.1016/j.techfore.2022.122205>.

## Conference papers

- [C1] T. Unterluggauer, S. Klyapovskiy, F. Hipolito, and P.B. Andersen (2022). "Impact of electric vehicle charging synchronization on the urban power distribution network of Frederiksberg," in: *35th International Electric Vehicle Symposium and Exhibition (EVS35)*, Oslo, Norway.
- [C2] T. Unterluggauer, K. Sevdari, and M. Marinelli (2024). "Technical demonstration of conditional connection agreements for urban EV charging clusters," in: *2nd International Conference on Renewable Energies and Smart Technologies*, Prishtina, Kosova.
- [C3] K. Sevdari, L. Calearo, S. Striani, P.B. Andersen, M. Marinelli, and L. Rønnow (2021). "Autonomously Distributed Control of Electric Vehicle Chargers for Grid Services," in: *Proceedings of ISGT Europe 2021 IEEE*, Espoo, Finland, <https://doi.org/10.1109/ISGTEurope52324.2021.9640132>.
- [C4] S. Striani, K. Sevdari, P. B. Andersen, M. Marinelli, Y. Kobayashi, and K. Suzuki (2022), "Autonomously Distributed Control of EV Parking Lot Management for Optimal Grid Integration," in: *International Conference on Renewable Energies and Smart Technologies (REST)*, Tirana, Albania, <https://doi.org/10.1109/REST54687.2022.10022907>.
- [C5] K. Sevdari, S. Striani, P. B. Andersen, and M. Marinelli (2022), "Power Modulation and Phase Switching Testing of Smart Charger and Electric Vehicle Pairs," in *57th International Universities Power Engineering Conference (UPEC)*, Istanbul, Turkey, 2022, <https://doi.org/10.1109/UPEC55022.2022.9917660>.
- [C6] S. Striani, K. Sevdari, M. Marinelli, V. Lampropoulos, Y. Kobayashi, and K. Suzuki (2022), "Wind Based Charging via Autonomously Controlled EV Chargers under Grid Constraints," in: *57th International Universities Power Engineering Conference (UPEC)*, Istanbul, Turkey, <https://doi.org/10.1109/UPEC55022.2022.9917883>.
- [C7] S. Striani, K. Sevdari, L. Calearo, P. B. Andersen, and M. Marinelli (2021), "Barriers and Solutions for EVs Integration in the Distribution Grid," in: *56th International Universities Power Engineering Conference (UPEC)*, Middlesbrough, United Kingdom, <https://doi.org/10.1109/UPEC50034.2021.9548235>.

## Student projects

- [S1] M. C. Jakobsen, "Experimental validation of emission based electric vehicles charging at a workplace", Bachelor thesis, May 2021
- [S2] A. Vicari, J. F. B. Busch-Knudsen, and L. J. Jonsdottir, "Emission based charging - Experimental validation of a marginal emission factor signal used for electric vehicle charging", Bachelor thesis, Jun 2021

- [S3] G. Fabbri, "Charging Infrastructure for Shared Parking Facilities with Dynamic Load Sharing", Bachelor thesis, Jun 2021
- [S4] S. H. Aggs, "The need and use of flexibility services in the distribution grid of Frederiksberg", Technical report, Jun 2021
- [S5] M. P. Polo, "Marginal Carbon Intensity for Electric Vehicle Charging - Benchmarking and Scaling", Master thesis, Jul 2021
- [S6] V. C. Foss and R. M. Knudsen, "Development of Harmonized Tests for Smart Electric Vehicle Charging across Charging Equipment", Technical report, Dec 2021
- [S7] G. Isaksen "Use of computer vision at fast-charging sites for detection of availability" (NONPUBLIC REPORT) , Technical report, Dec 2021
- [S8] S. H. Aggs, "Impact of electric vehicle flexibility services and charging infrastructure rollouts on urban distribution transformers", Master thesis, Feb 2022
- [S9] M. F. Jørgensen, "Experimental Validation of Smart Charging at a Workplace Charging Lot", Bachelor thesis, Jun 2022
- [S10] A. I. Gaskue, "Grid impacts from combinations of marked-based electric vehicle charging profiles", Master thesis, Jun 2022
- [S11] V. C. Foss and R. M. Knudsen, "Test and Implementation of Grid Flexibility Services at Public Charging Sites", Technical report, Dec 2022
- [S12] S. Mangifesta, "Experimental validation of smart charging strategies on a parking lot", Master thesis, Feb 2023
- [S13] V. C. Foss and R. M. Knudsen, "Smart from Start - Experimental Validation of Dynamic Charging Limits via EVSE", Bachelor thesis, Feb 2023
- [S14] J. Dagø "Scaling and optimization of charging capacity at a workplace" , Bachelor thesis, Feb 2023
- [S15] C. M. Zacho Hansen and A. Thrane, "Experimental tests of smart charging in the municipality of Frederiksberg", Bachelor thesis, Jun 2023
- [S16] J. C. Langert, "Frequency regulation from electric vehicles - feasibility study and experimental validation", Technical report, Jun 2023